

QMP 7.1 D/F



**Channabasaveshwara Institute of Technology**

(An ISO 9001:2008 Certified Institution)

NH 206 (B.H. Road), Gubbi, Tumkur – 572 216. Karnataka.



Department of Mechanical Engineering

Fluid Mechanics Laboratory

15MEL57

B.E - V Semester

Lab Manual 2017-18

Name: \_\_\_\_\_

USN : \_\_\_\_\_

Batch : \_\_\_\_\_ Section : \_\_\_\_\_



**Channabasaveshwara Institute of Technology**

(An ISO 9001:2008 Certified Institution)

NH 206 (B.H. Road), Gubbi, Tumkur – 572 216. Karnataka.

QMP 7.1 D/F



Department of Mechanical Engineering

# Fluid Mechanics Lab Manual

Version 2.0

August 2017

**Prepared by:**

Mr. Somesha . G H

Assistant Professor

**Reviewed by:**

Mr. Nagesh S B

Assistant Professor

**Approved by:**

Professor & Head,

Dept. of ME

**Channabasaveshwara Institute of Technology****(An ISO 9001:2008 Certified Institution)****NH 206 (B.H. Road), Gubbi, Tumkur – 572 216. Karnataka.****DEPARTMENT OF MECHANICAL ENGG.****FLUID MECHANICS LABORATORY- SYLLABUS****Subject Code : 15MEL57****Hours/Week : 03****Total Hours : 42****IA Marks : 20****Exam Hours : 03****Exam Marks : 80****PART-A:**

1. Lab layout, calibration of instruments and standards to be discussed
2. Determination of co-efficient of friction of flow in a pipe
3. Determination of minor losses in flow through pipes
4. Application of momentum equation for determination of coefficient of impact of jets on flat and curved blades
5. Calibration of flow measuring devices:
  - a) Orifice plate meter
  - b) Nozzle meter
  - c) Venturimeter
  - d) V-notch

**PART-B:**

6. Performance on hydraulic turbines:
  - a) Pelton wheel
  - b) Francis turbine
  - c) Kaplan turbine.
7. Performance on hydraulic pumps:
  - a) Single stage and multi stage centrifugal pumps
  - b) Reciprocating pump.
8. Performance test of a two stage reciprocating air compressor
9. Performance test on an air blower

**PART-C (optional)**

10. Visit to hydraulic power station/Municipal water pump house and case studies.
11. Demonstration of cut section models of hydraulic turbines and pumps.

**Scheme of Examination:**

ONE question from part -A: 25 Marks

ONE question from part -B: 40 Marks

Viva -Voice: 15 Marks.

Total : 80 Marks.



**Channabasaveshwara Institute of Technology****(An ISO 9001:2008 Certified Institution)****NH 206 (B.H. Road), Gubbi, Tumkur – 572 216. Karnataka.****DEPARTMENT OF MECHANICAL ENGG.****Course Objectives**

1. This course will provide a basic understanding of flow measurements using various types of flow measuring devices, calibration and losses associated with these devices.
2. Energy conversion principles, analysis and understanding of hydraulic turbines and pumps will be discussed. Application of these concepts for these machines will be demonstrated. Performance analysis will be carried out using characteristics curves.

**Course Outcomes**

1. Perform experiments to determine the coefficient of discharge of flow measuring devices.
2. Conduct experiments on hydraulic turbines and pumps to draw characteristics.
3. Test basic performance parameters of hydraulic turbines and pumps and execute the knowledge in real life situations.
4. Determine the energy flow pattern through the hydraulic turbines and pumps.
5. Exhibit his competency towards preventive maintenance of hydraulic turbines.

**Channabasaveshwara Institute of Technology****(An ISO 9001:2008 Certified Institution)****NH 206 (B.H. Road), Gubbi, Tumkur – 572 216. Karnataka.****DEPARTMENT OF MECHANICAL ENGG.****General Instructions to the Students.**

- ✓ Laboratory uniform, shoes & safety glasses are compulsory in the lab.
- ✓ Do not touch anything with which you are not completely familiar. Carelessness may not only break the valuable equipment in the lab but may also cause serious injury to you and others in the lab.
- ✓ Please follow instructions precisely as instructed by your supervisor. Do not start the experiment unless your setup is verified & approved by your supervisor.
- ✓ Do not leave the experiments unattended while in progress.
- ✓ Do not crowd around the equipment's & run inside the laboratory.
- ✓ During experiments material may fail and disperse, please wear safety glasses and maintain a safe distance from the experiment.
- ✓ If any part of the equipment fails while being used, report it immediately to your supervisor. Never try to fix the problem yourself because you could further damage the equipment and harm yourself and others in the lab.
- ✓ Keep the work area clear of all materials except those needed for your work and cleanup after your work.



## **Channabasaveshwara Institute of Technology**

**(An ISO 9001:2008 Certified Institution)**

**NH 206 (B.H. Road), Gubbi, Tumkur – 572 216. Karnataka.**



### **DEPARTMENT OF MECHANICAL ENGINEERING.**

<b>Sl. No</b>	<b>Particulars</b>	<b>Page No</b>
1	Nomenclature of standard terms	01
2	Determination of co-efficient of friction of flow in a pipe	02
3	Determination of minor losses in flow through pipes	06
4	Determination of force developed by impact of jets on vanes	10
5	Calibration of flow measuring devices : Orifice plate meter	14
6	Venturimeter	18
7	Nozzle meter	22
8	V-notch	26
9	Performance testing of turbines: Pelton wheel	30
10	Francis turbine	36
11	Kaplan turbine	42
12	Performance testing of: single stage centrifugal pump	48
13	Reciprocating pump	52
14	Performance test of a two stage reciprocating air compressor	56
15	Performance test on an air blower	60
16	Viva - Voice	64
17	References	67

**Nomenclature of standard terms:**

Specific weight of water,  $\omega = 9810 \text{ N/m}^3$

Acceleration due to gravity,  $g = 9.81 \text{ m/s}^2$

Specific gravity of mercury,  $S_{\text{Hg}} = 13.6$

Specific gravity of water,  $S_w = 1$

Density of water,  $\rho_w = 1000 \text{ kg/m}^3$

Density of air,  $\rho_a = 1.2 \text{ kg/m}^3$

Density of mercury,  $\rho_{\text{Hg}} = 13600 \text{ kg/m}^3$



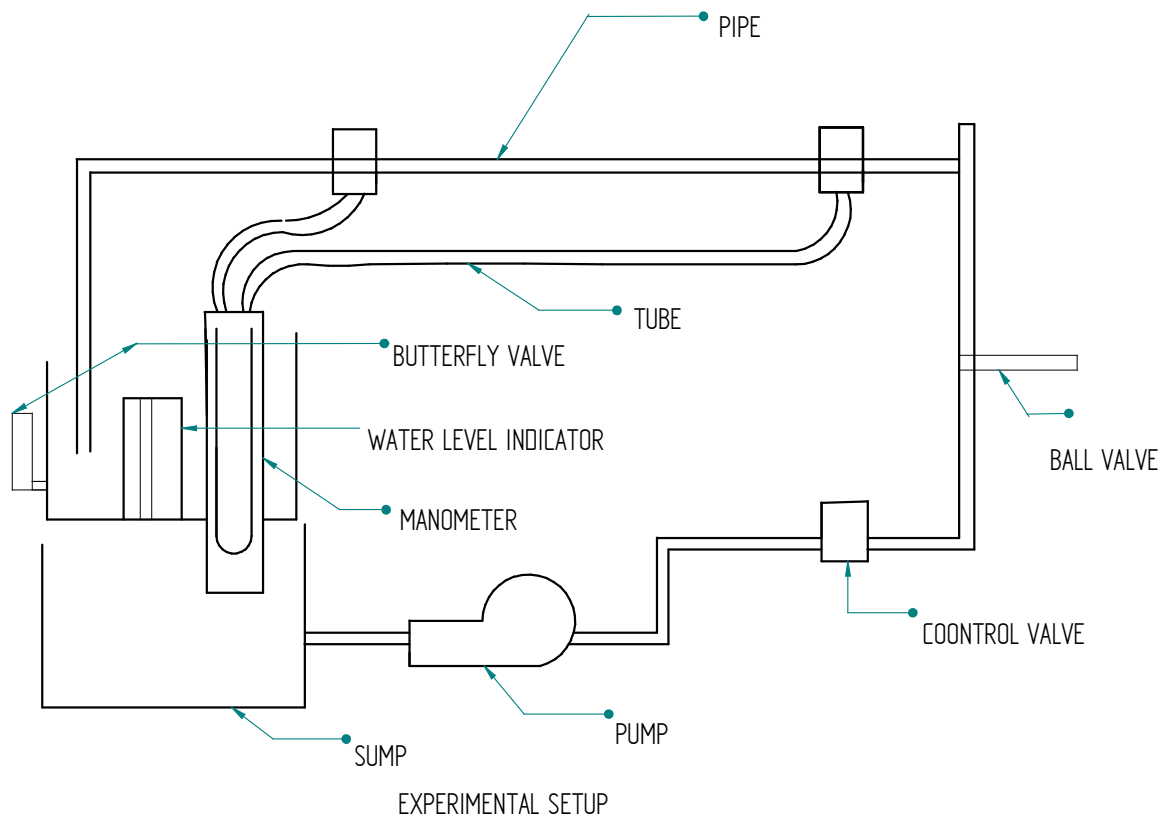

**Observations and Calculations:**

Area of Tank = m<sup>2</sup>  
 Length of pipe, L = m

**Formulae:**

Discharge Q =  $\frac{AR}{t}$  m<sup>3</sup>/s

Where, R = Rise in water level in collecting tank. (In m)  
 t = time in seconds.

Velocity of flow, V =  $\frac{Q}{a}$  m/s

Q = Discharge in m<sup>3</sup>/s

Cross sectional area of pipe a =  $\frac{\pi d^2}{4}$  m<sup>2</sup> where 'd' is inner diameter of pipe in m.

Co efficient of friction, f =  $\frac{h_f 2gd}{4LV^2}$

**Experiment No. 01****FRICION IN PIPES**

**Aim:** To determine the Co-efficient of friction in flow through pipes of various sizes.

**Theory:**

When a fluid is flowing through a pipe, the fluid experiences some resistance due to which some of the energy of fluid is lost. The loss of energy is classified into

1. Major energy loss: this is due to friction and it is calculated by the following formulae:

a) Darcy-Weisbach Formula 
$$h_f = \frac{4fLV^2}{2gd}$$

Where,

$h_f$  = loss of head due to friction  
 $f$  = co-efficient of friction which is a function of Reynolds number.

$$= \frac{16}{R_e} \text{ for } R_e < 2000$$

$$= \frac{0.079}{R_e^{1/4}} \text{ for } R_e \text{ varying from } 4000 \text{ to } 10^6$$

$L$  = length of pipe

$V$  = mean velocity of flow

$d$  = diameter of pipe.

- b) Chezy's formula

$$V = C\sqrt{mi}$$

Where,

$C$  = Chezy's Constant

$m$  for pipe is always equal to  $\frac{d}{4}$

$i$  = loss of head due to friction/unit length of pipe.

**Procedure:**

1. Switch on the pump and open the delivery valve.
  2. Open the corresponding ball valve of pipe under consideration.
  3. Keep the ball valve of other pipeline closed.
  4. Note down the differential head readings in the manometer. (Expel if any air is present by opening the drain cocks provided to the manometer).
  5. Close the butterfly valve and note down the time taken for known water level rise.
- where  $h_f$  is loss of head.

$$h_f = H \left[ \frac{S_{Hg}}{S_w} - 1 \right] \text{ m of water.}$$

$H$  = Manometer reading in m of Hg

6. Change the flow rate and take the corresponding reading
7. Repeat the experiment for different diameter of pipelines.

**Table of calculations:**

Type	Difference in Mercury level			Rise of water in m	Time taken in sec	Discharge $Q$ ( $m^3/s$ )	Velocity $V$ (m/s)	Loss of head in m	Co-efficient of Friction
	$h_1$	$h_2$	$H = h_1 - h_2$ in m						

Work Sheet

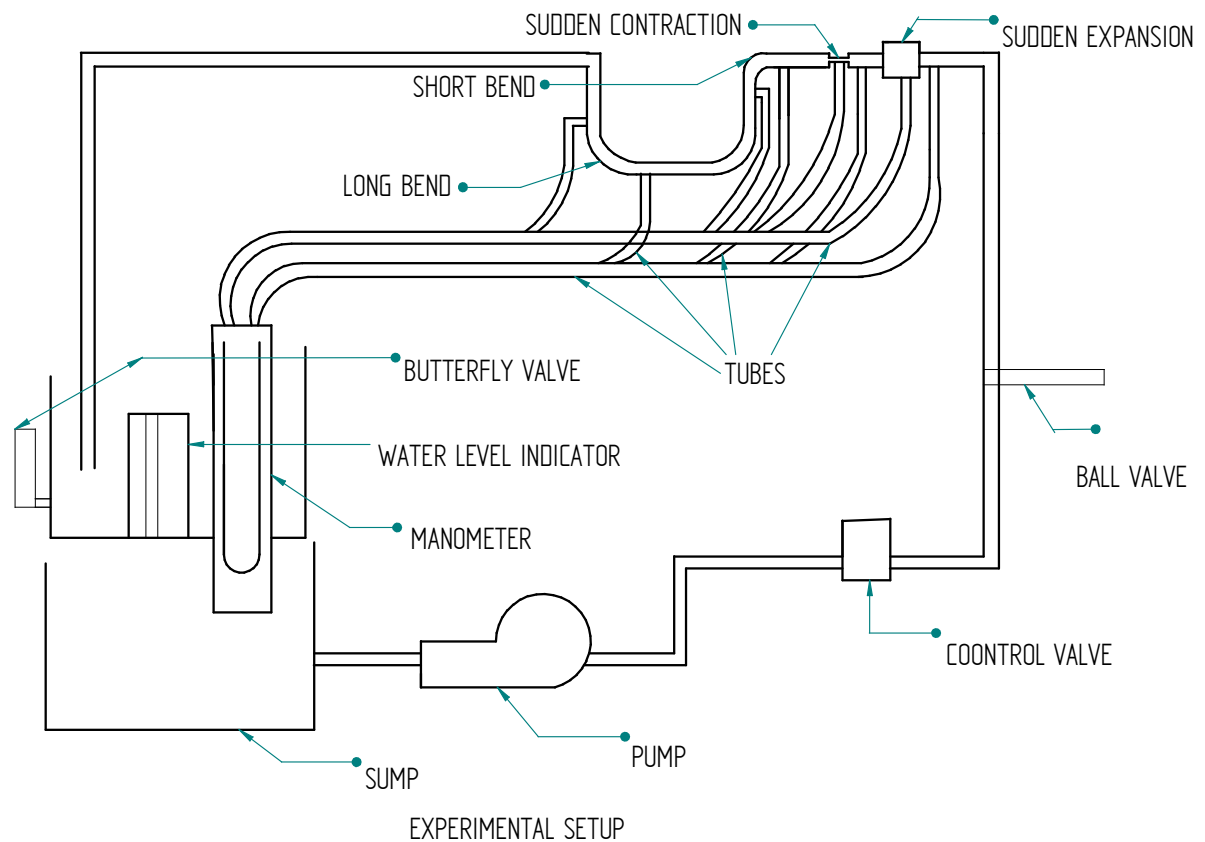
**Observations.**

Area of Tank,  $A = 0.125 \text{ m}^2$

**Formulae:**

$$\text{Discharge } Q = \frac{AR}{t} \text{ m}^3/\text{s}$$

Where,  $R =$  Rise in water level in collecting tank. (In m)  
 $t =$  time in seconds.

$$\text{Velocity of flow, } V = \frac{Q}{a} \text{ m/s}$$

Cross sectional area of pipe  $a = \frac{\pi d^2}{4} \text{ m}^2$  where 'd' is inner diameter of pipe.

Loss of energy due to sudden expansion.

$$h_L = \frac{(V_1 - V_2)^2}{2g} \text{ Where } V_1 \text{ and } V_2 \text{ are velocities of flow before and after expansion.}$$

**Experiment No. 02****MINOR LOSSES IN FLOW THROUGH PIPES**

**Aim:** To determine various minor losses of energy in flow through pipes.

**Theory:**

When a fluid flows through a pipe, certain resistance is offered to the flowing fluid, which results in causing a loss of energy. The various energy losses in pipes may be classified as:

- (i) Major losses.
- (ii) Minor losses.

The major loss of energy as a fluid flows through a pipe, is caused by friction. It may be computed mainly by Darcy-Weisbach equation. The loss of energy due to friction is classified as a major loss because in case of long pipelines. It is usually much more than the loss of energy incurred by other causes.

The minor losses of energy are those, which are caused on account of the change in the velocity of flowing fluid (either in magnitude or direction). In case of long pipes these losses are usually quite small as compared with the loss of energy due to friction and hence these are termed 'minor losses' which may even be neglected without serious error. However, in short pipes these losses may sometimes outweigh the friction loss. Some of the losses of energy that may be caused due to the change of velocity are indicated below

- (a) Loss of energy due to sudden enlargement.

$$h_L = \frac{(V_1 - V_2)^2}{2g}$$

- (b) Loss of energy due to sudden contraction

$$h_L = 0.375 \frac{V^2}{2g}$$

- (c) Loss of energy at 90° Elbow

$$h_L = 0.75 \frac{V^2}{2g}$$

- (d) Loss of energy at 90° Bend

$$h_L = 0.45 \frac{V^2}{2g}$$

Table of calculations:

Type	Difference in Mercury level			Rise of water in m	Time taken in sec	Discharge Q (m <sup>3</sup> /s)	Velocity V (m/s)		Loss of head in m h <sub>f</sub>
	h <sub>1</sub>	h <sub>2</sub>	H= h <sub>1</sub> -h <sub>2</sub> in m						

**Procedure:**

1. Switch on the pump and open the delivery valve.
2. Open the corresponding ball valve of pipe under consideration.
3. Keep the ball valves of other pipelines closed.
4. Note down the differential head readings in the manometer.(expel if any air is present by opening the drain cocks provided to the manometer).
5. Close the butterfly valve and note down the time taken for known water level rise.
6. Change the flow rate and take the corresponding reading



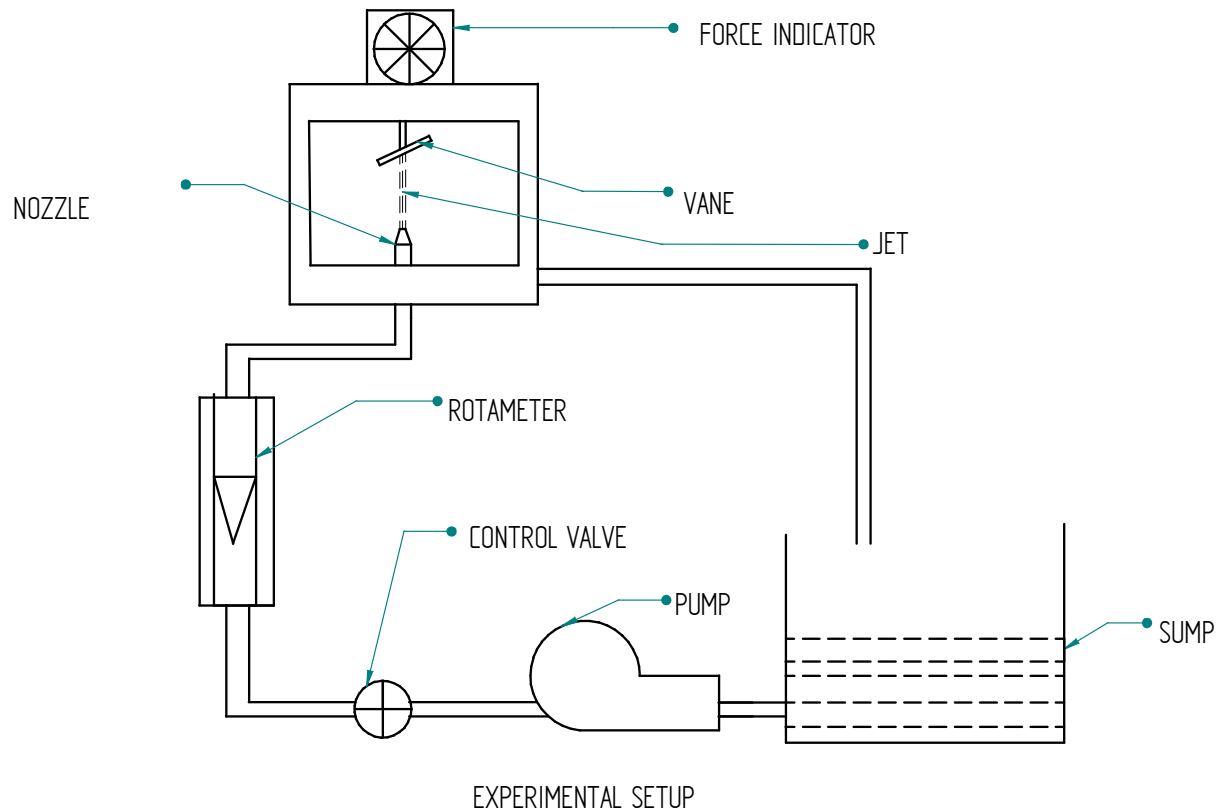

### Observations and Calculations:

#### Formulae:

Cross section area of jet  $a = \frac{\pi d^2}{4} \text{ m}^2$

Where, d is diameter of the jet in m.

Velocity of jet,  $V = Q/a \text{ m/s}$  Where Q is discharge in  $\text{m}^3/\text{s}$

Theoretical force,

$$F_{\text{the}} = \rho a V^2 \text{ N} \quad [\text{flat plate}]$$

$$F_{\text{the}} = 2\rho a V^2 \text{ N} \quad [\text{Hemispherical plate}]$$

$$F_{\text{the}} = \rho a V^2 \sin^2\theta \text{ N} \quad [\text{Inclined plate}]$$

Actual force =  $F_{\text{act}}$  (observed in force indicator).

$$\text{Co-efficient of impact, } k = \frac{F_{\text{act}}}{F_{\text{the}}}$$

**Experiment No. 03****IMPACT OF JET ON VANES**

**Aim:** To determine the co-efficient of impact on vanes

**Theory:**

The liquid comes out in the form of a jet from the outlet of a nozzle, which is fitted to a pipe through which the liquid is flowing under pressure. If some plate, which may be fixed or moving, is placed in the path of the jet, the jet on the plate exerts a force. This force is obtained from Newton's second law of motion or from impulse momentum equation. Thus impact of jet means the force excited by the jet on a plate, which may be stationary or moving.

- a) Force exerted by the jet on a stationary plate is when,
  - i) Plate is vertical to jet
  - ii) plate is inclined to jet
  - iii) Plate is curved.
- b) Force exerted by the jet on a moving plate is when
  - i) Plate is vertical to jet
  - ii) plate is inclined to jet.
  - iii) Plate is curved.

**Apparatus used:**

1. Vanes (flat, inclined with  $\theta = 60^\circ$  and hemispherical), experimental setup comprising rotameter, nozzles of different diameter, steady supply of water using pump.

**Procedure:**

1. Fix the required diameter of nozzle and the vane of the required shape in position.
2. Bring the force indicator position to zero.
3. Keep the delivery valve closed and switch on the pump.
4. Close the front transparent glass tightly.
5. Open the delivery valve and adjust the flow rate.
6. Observe the force as indicated on the force indicator.
7. Note down the diameter of the pipe of the jet and shape of the vane and the discharge is calculated.

Table of readings:

Type of Vane	Dia of Jet, d (m)	Q	Force indicator $F_{act}$	
		$m^3/s$	kgf	N
Hemispherical				
Flat				
Inclined				

**Table of calculations:**

Type of vane	Dia of jet d (m)	$F_{the}$	$k = \frac{F_{act}}{F_{the}}$	Avg. k

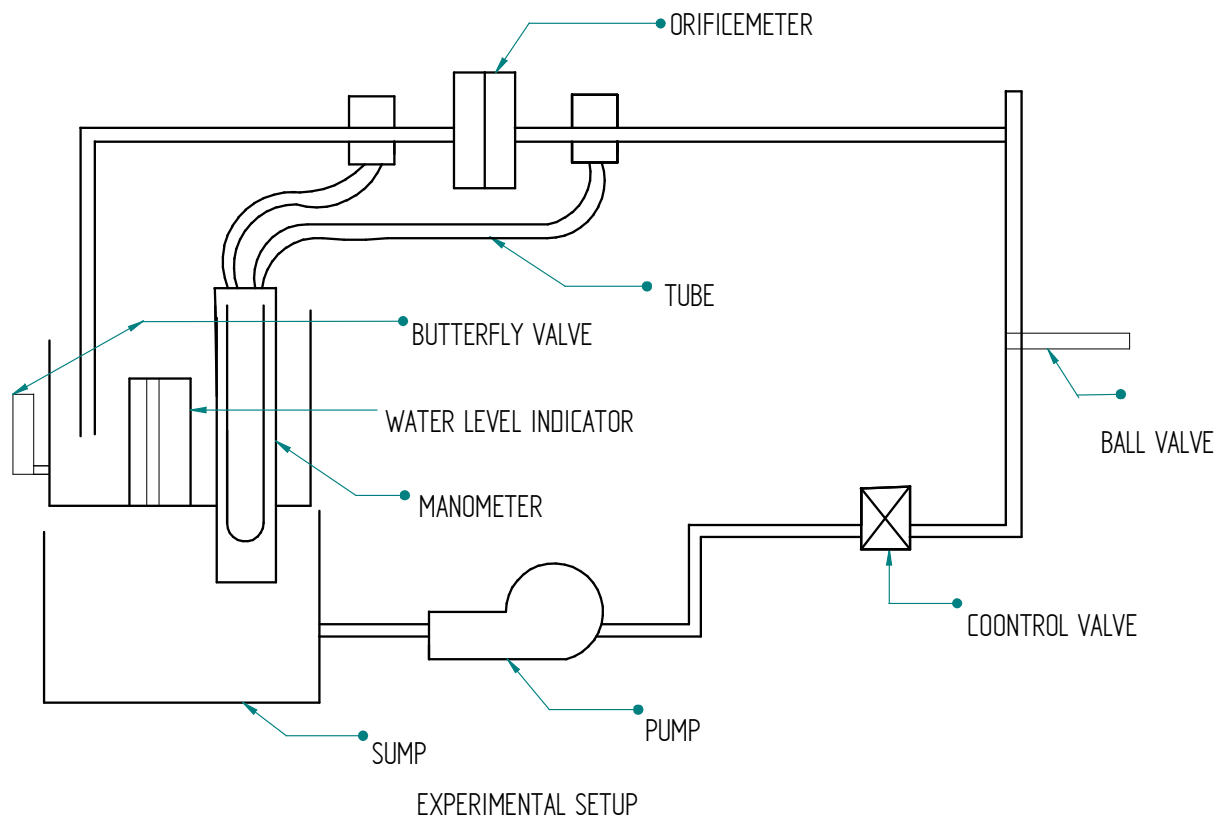
**Observation and Calculation:**

Internal diameter of pipe	$d_1 = 0.025 \text{ m}$
Orifice diameter	$d_2 = 0.015 \text{ m}$
Area of Collecting Tank	$A = 0.0125 \text{ m}^2$

**Formulae:**

Cross sectional area of pipe,  $a_1 = \frac{\pi d_1^2}{4} \text{ m}^2$

Cross sectional area of orifice,  $a_2 = \frac{\pi d_2^2}{4} \text{ m}^2$

Actual discharge,  $Q_{\text{act}} = \frac{AR}{t} \text{ m}^3/\text{s}$  where R = rise in water level in collection tank (in m).

Theoretical discharge,  $Q_{\text{the}} = \frac{a_1 a_2 \sqrt{2gh}}{\sqrt{a_1^2 - a_2^2}} \text{ m}^3/\text{s}$  where head,  $h = x \left[ \frac{S_{\text{Hg}}}{S_w} - 1 \right]$  m of water.

**Experiment No. 04****ORIFICE METER**

**Aim:** To determine the co-efficient of discharge through orifice meter.

**Theory:**

Orifice meter is a device used to measure discharge in a pipeline or a closed conduit. Orifice is a hole through which liquid is made to pass through. It works on Bernoulli's principle or venturi effect and continuity equation.

Orifice meter consists of a flat plate with a circular hole at the centre. The circular hole is called orifice. The edges of the orifice are bevelled. The orifice plate is fixed using flanges. The section of flow where the area is minimum is called venacontracta. At venacontracta the velocity is maximum.

Merits and Demerits of orifice meter over venturimeter.

- Orifice meter occupies less space than venturimeter.
- Simple in construction and hence cheaper than venturimeter.
- In case of orifice meter expansion and contraction are sudden and hence loss of energy is more.
- The co-efficient of discharge of venturimeter is high (about 0.9) where as that of orifice meter is low (about 0.6).

**Apparatus used:**

1. Orifice meter
2. Pump and motor for steady supply of water.
3. Clock to record the time
4. Measuring tank.

**Procedure:**

1. Fill the sump with clean water. Keep the delivery valve closed. Open the corresponding ball valve of the orifice meter pipeline.
2. Adjust the flow through the control valve of pump.
3. Open the corresponding ball valve fitted to orifice meter tank tapings.
4. Note down the difference head readings in manometer.
5. Operate the butterfly valve to note down the time taken for a known amount of rise in water level in collecting tank.
6. Change the flow rate and repeat the experiment.
7. Calculate co-efficient of discharge using relevant formula.

**Graph to be plotted**

Log  $Q_{act}$  Vs  $l_{gh}$  and calculate the slope

$x$  = Manometer reading in m of Hg

$$Q_{\text{the}} = k \times h^{\frac{1}{2}} \text{ m}^3/\text{s} \text{ (Where } n = 1/2)$$

$$k = \frac{a_1 a_2 \sqrt{2g}}{\sqrt{a_1^2 - a_2^2}}$$

Co-efficient of discharge,  $C_d = \frac{Q_{\text{act}}}{Q_{\text{the}}}$

**Table of readings:**

Sl	R (m)	t (s)	Manometer reading x		Water Head (h) m of water
			mm	m	

**Table of calculations:**

Sl	$Q_{\text{act}}$ ( $\text{m}^3/\text{s}$ )	$Q_{\text{the}}$ ( $\text{m}^3/\text{s}$ )	$C_d = \frac{Q_{\text{act}}}{Q_{\text{the}}}$	Avg. $C_d$

Work Sheet



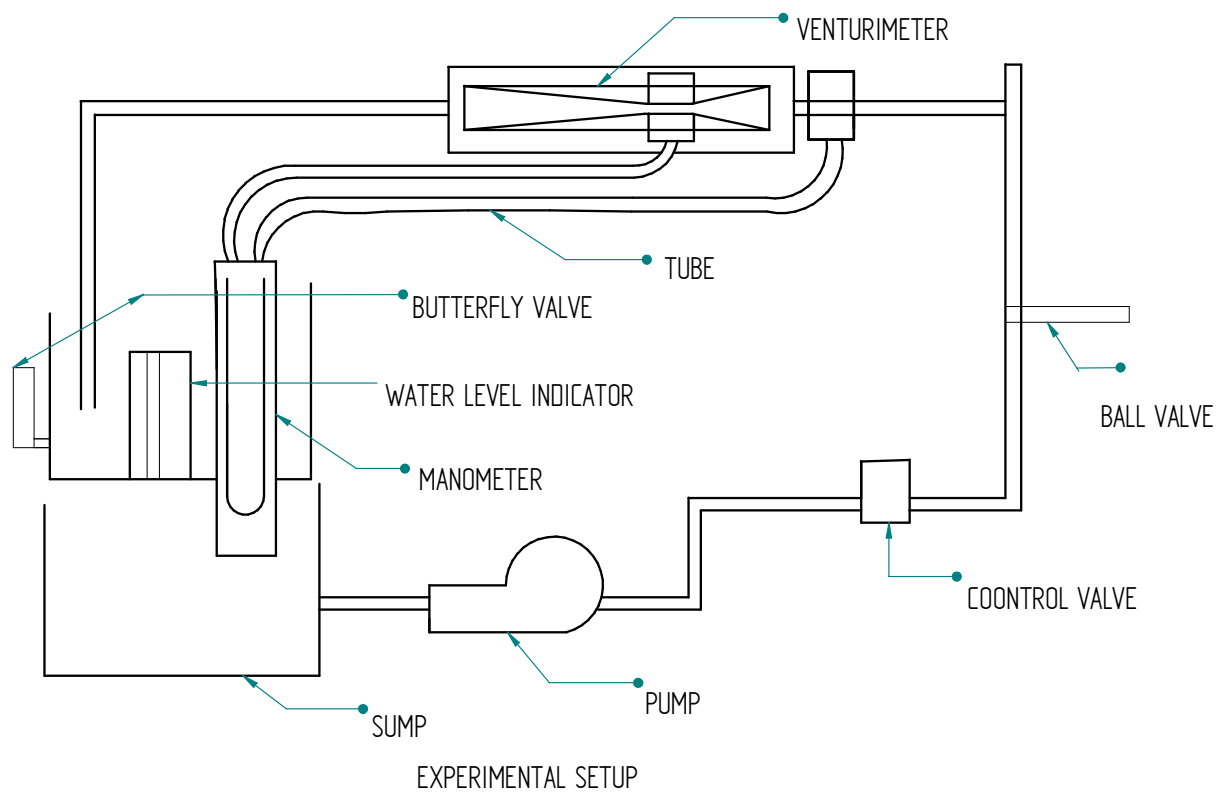

**Observation and Calculation:**

Inlet diameter of venturimeter,  $d_1 =$             m  
 Throat diameter of venturimeter,  $d_2 =$             m  
 Area of Collecting Tank,  $A =$             m<sup>2</sup>

**Formulae:**

Cross sectional area of inlet,  $a_1 = \frac{\pi d_1^2}{4}$  m<sup>2</sup>

Cross sectional area of throat,  $a_2 = \frac{\pi d_2^2}{4}$  m<sup>2</sup>

Actual discharge  $Q_{act} = \frac{AR}{t}$  m<sup>3</sup>/s where R = rise in water level in collection tank (in m).

Theoretical discharge,  $Q_{the} = \frac{a_1 a_2 \sqrt{2gh}}{\sqrt{a_1^2 - a_2^2}}$  m<sup>3</sup>/s where head,  $h = x \left[ \frac{S_{Hg}}{S_w} - 1 \right]$  m of water.

$x =$  Manometer reading in m of Hg

**Experiment No. 05****VENTURIMETER.**

**Aim:** To determine the co-efficient of discharge through Venturimeter.

**Theory:**

Venturimeter is a device used to measure discharge of fluid in a closed conduit or pipeline. It consists of a convergent cone, throat and divergent cone. As the area of the flow decreases in the convergent cone, velocity of flow increases and pressure decreases. The measurement of pressure difference between the inlet section and throat section leads to the measurement of discharge. The angle of divergent cone will be  $60^\circ$  and that of convergent cone will be about  $20^\circ$ . The length of the divergent cone will be more than the length of convergent cone. The dia of the throat will be 0.5-0.6 times the dia of the pipeline or the inlet section.

If a fluid is made to flow through a varying section due to the variation in pressure, there will be variation in velocity and this effect is known as ventur effect.

**Apparatus used:**

1. Venturimeter
2. Pump and motor for steady supply of water.
3. Clock to record the time
4. Measuring tank.

**Procedure:**

1. Fill the sump with clean water. Keep the delivery valve closed. Open the ball valve of the venturimeter pipeline.
2. Adjust the flow through the control valve of pump.
3. Open the corresponding ball valve fitted to Venturi meter tank tapings.
4. Care should be taken, such that there should be not any air bubble, while the liquid is passing through the manometer.
5. The differential reading of the manometer is noted down from the level of Hg in two limbs.
6. Then the time required to collect 200 mm of water in the collecting tank is noted down.
7. Finally the procedure is employed for different discharge through the pipeline.

**Graph to be plotted**

Log  $Q_{act}$  Vs logh and calculate the slope

$$Q_{\text{the}} = k \times h^{\frac{1}{2}} \text{ m}^3/\text{s} \text{ (Where } n = 1/2)$$

$$k = \frac{a_1 a_2 \sqrt{2g}}{\sqrt{a_1^2 - a_2^2}}$$

Co-efficient of discharge,  $C_d = \frac{Q_{\text{act}}}{Q_{\text{the}}}$

**Table of readings:**

Sl No	R(m)	t(s)	Manometer Reading (x)		Water Head (h) m of water
			mm of Hg	m of Hg	

**Table of calculations:**

Sl	$\frac{Q_{\text{act}}}{\left(\frac{\text{m}^3}{\text{s}}\right)}$	$\frac{Q_{\text{the}}}{\left(\frac{\text{m}^3}{\text{s}}\right)}$	$C_d = \frac{Q_{\text{act}}}{Q_{\text{the}}}$	Avg. $C_d$

**Work Sheet**

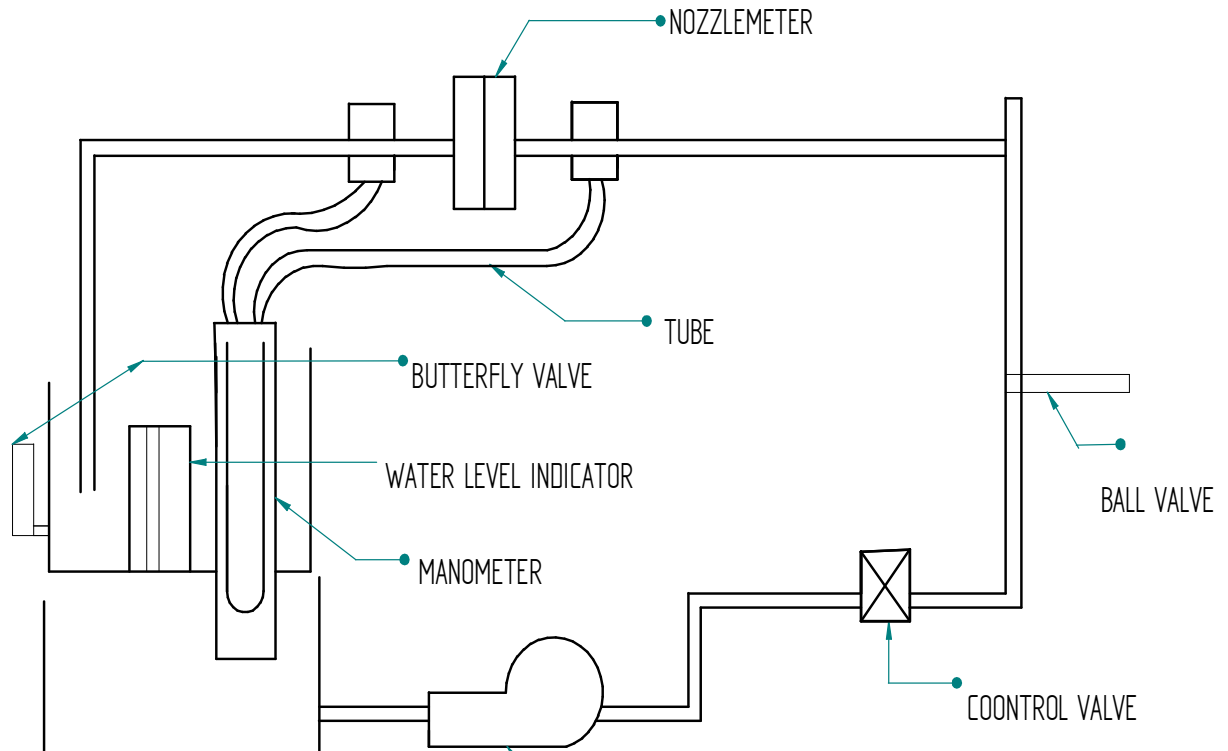

**Observation and Calculation:**

Inlet diameter of Nozzle,	$d_1 =$	m
Exit diameter of Nozzle,	$d_2 =$	m
Area of Collecting Tank,	$A =$	$m^2$

**Formulae:**

Cross sectional area of inlet,  $a_1 = \frac{\pi d_1^2}{4} \text{ m}^2$

Cross sectional area of exit,  $a_2 = \frac{\pi d_2^2}{4} \text{ m}^2$

Actual discharge  $Q_{act} = \frac{AR}{t} \text{ m}^3/s$  where R = rise in water level in collection tank (in m).

Theoretical discharge,  $Q_{the} = \frac{a_1 a_2 \sqrt{2gh}}{\sqrt{a_1^2 - a_2^2}} \text{ m}^3/s$  where head,  $h = x \left[ \frac{S_{Hg}}{S_w} - 1 \right]$  m of water.

$$x = \text{Manometer reading in m of Hg}$$

Experiment No. 06

### **FLOW NOZZLE APPARATUS.**

**Aim:** To determine the co-efficient of discharge through a nozzle meter.

**Theory:**

Flow nozzle is a device used to measure discharge of fluid in a closed conduit or pipeline. It is mainly used for metering fluids flowing under high pressure thorough lines of minimum size due to some reason, another advantage of flow nozzle is that it requires smaller piping before & after the primary element as compared that of an orifice meter.

**Apparatus used:**

1. Nozzle meter
2. Pump and motor for steady supply of water.
3. Clock to record the time
4. Measuring tank.

**Procedure:**

1. Fill the sump with clean water. Keep the delivery valve closed. Open the ball valve of the venturimeter pipeline.
2. Adjust the flow through the control valve of pump.
3. Open the corresponding ball valve fitted to Venturi meter tank tapings.
4. Care should be taken, such that there should be not any air bubble, while the liquid is passing through the manometer.
5. The differential reading of the manometer is noted down from the level of Hg in two limbs.
6. Then the time required to collect 200 mm of water in the collecting tank is noted down.
7. Finally the procedure is employed for different discharge through the pipeline.

**Graph to be plotted**

Log  $Q_{act}$  Vs logh and calculate the slope

$$Q_{\text{the}} = k \times h^{\frac{1}{2}} \text{ m}^3/\text{s} \text{ (Where } n = 1/2\text{)}$$

$$k = \frac{a_1 a_2 \sqrt{2g}}{\sqrt{a_1^2 - a_2^2}}$$

$$\text{Co-efficient of discharge, } C_d = \frac{Q_{\text{act}}}{Q_{\text{the}}}$$

**Table of readings:**

Sl No	R(m)	t(s)	Manometer Reading (x)		Water Head (h) m of water
			mm of Hg	m of Hg	

**Table of calculations:**

Sl	$\frac{Q_{\text{act}}}{\left(\frac{\text{m}^3}{\text{s}}\right)}$	$\frac{Q_{\text{the}}}{\left(\frac{\text{m}^3}{\text{s}}\right)}$	$C_d = \frac{Q_{\text{act}}}{Q_{\text{the}}}$	Avg. $C_d$

Work Sheet



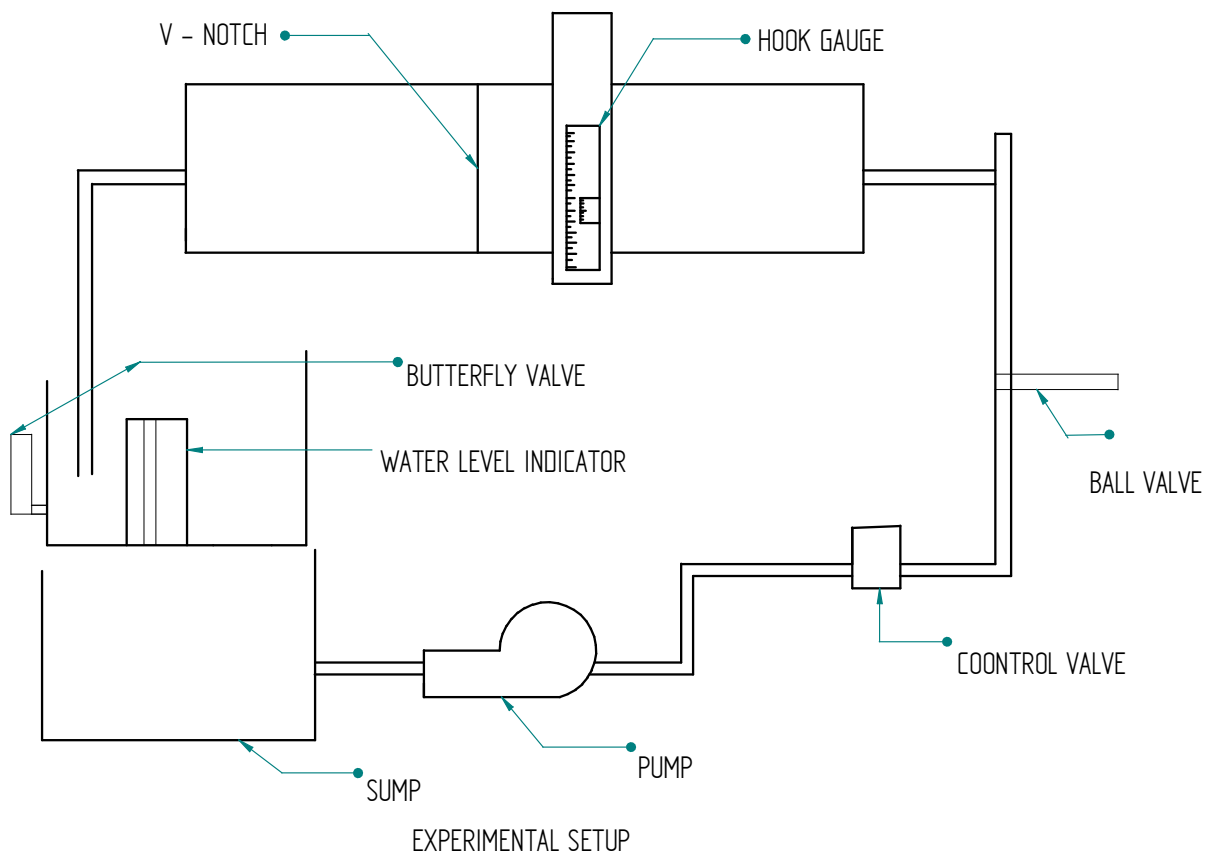
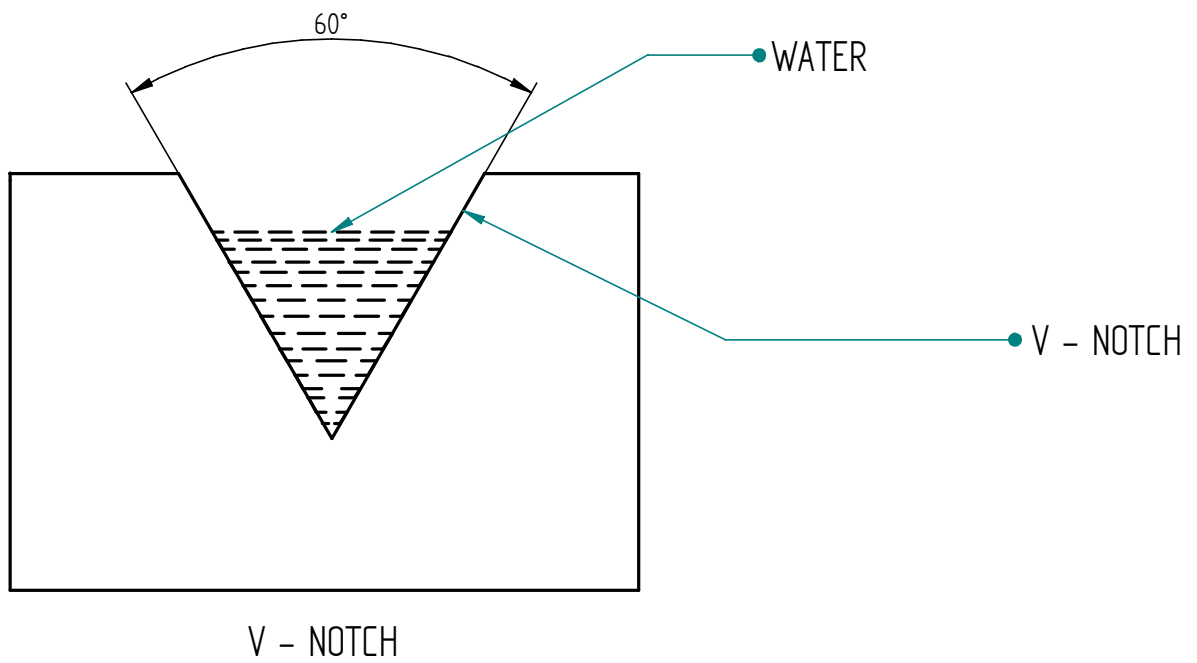

**Experiment No. 07****TRIANGULAR NOTCH**

**Aim:** To Determine the Co-efficient of Discharge through triangular notch and to calibrate given triangular notch

**Theory:**

A notch is a device used for measuring the rate of flow of liquid through a small channel (or) a tank.

Applications:

- b) For finding the discharge of flowing water.
- c) Velocity of flowing water can be determined.

Advantages:

- b) Easy to calculate discharge.
- c) Can be used in wide channels too.

Disadvantages:

- a) Ventilation for notch is necessary.
- b) Less accurate results are obtained, while measuring discharge.

Co-efficient of discharge is defined as the ratio of the actual discharge to the theoretical discharge. It is denoted by  $C_d$ .

$$\text{i.e } C_d = \frac{Q_{\text{act}}}{Q_{\text{the}}}$$

Expressions for  $Q_{\text{the}}$  for triangular notch(V notch) is given as,

$$Q_{\text{the}} = \frac{8}{15} \tan \frac{\theta}{2} \sqrt{2g} \times H^{\frac{5}{2}}$$

**Apparatus Required:**

2. Approach channel with baffle plate fitted with notch,
3. A Surface level gauge to measure head over notch.
4. A measuring tank to measure flow rate.
5. A constant steady supply of water with using pump.

**Procedure:**

1. Fix the triangular notch at the end of the approach channel with sharp edge on the upstream side.
2. Fill the channel with water up to the crest level and adjust the hook gauge reading to zero.
3. Adjust the flow by control valve to give maximum possible discharge and wait until head over the sill of the notch. Note down the final hook gauge reading causing flow over the notch

**Observations and Calculations:**

$$\begin{aligned} \text{Area of collecting tank (A)} &= \text{m}^2 \\ \text{Breadth of tank (b)} &= \text{m} \\ \text{Angle of V notch } (\theta) &= \end{aligned}$$

**Formulae:**

$$\text{Actual discharge, } Q_{\text{act}} = \frac{AR}{t} \text{ m}^3/\text{s}$$

Where,

A = Area of collecting tank in metre.

R = Rise of water level in collecting tank in metre.

t = time in seconds.

$$\text{Theoretical discharge, } Q_{\text{the}} = \frac{8}{15} \tan \frac{\theta}{2} \sqrt{2g} \times H^{\frac{5}{2}} \text{ m}^3/\text{s}$$

Where,

H = Head over notch in metre = FR - IR

$$\text{Co-efficient of discharge, } C_d = \frac{Q_{\text{act}}}{Q_{\text{the}}}$$

**Graph to be plotted:**

Log  $Q_{\text{act}}$  Vs log H and calculate the slope

**Table of Readings:**

Sl. No.	Discharged water		Hook gauge reading				Head Over notch H (m)
	R (m)	t (s)	IR		FR		
			mm	m	mm	m	

- 4) Collect the water flowing over the notch in the measuring tank and measure the rise in water level 'R' in the tank for 't' sec.
- 5) Lower the water level in approach channel in stages by varying the flow by control valve and record the series of readings.

**Table of Calculations:**

Sl	$Q_{act}$ $(\text{m}^3/\text{s})$	$Q_{the}$ $(\text{m}^3/\text{s})$	$C_d = \frac{Q_{act}}{Q_{the}}$	Avg. $C_d$

## Pelton Wheel

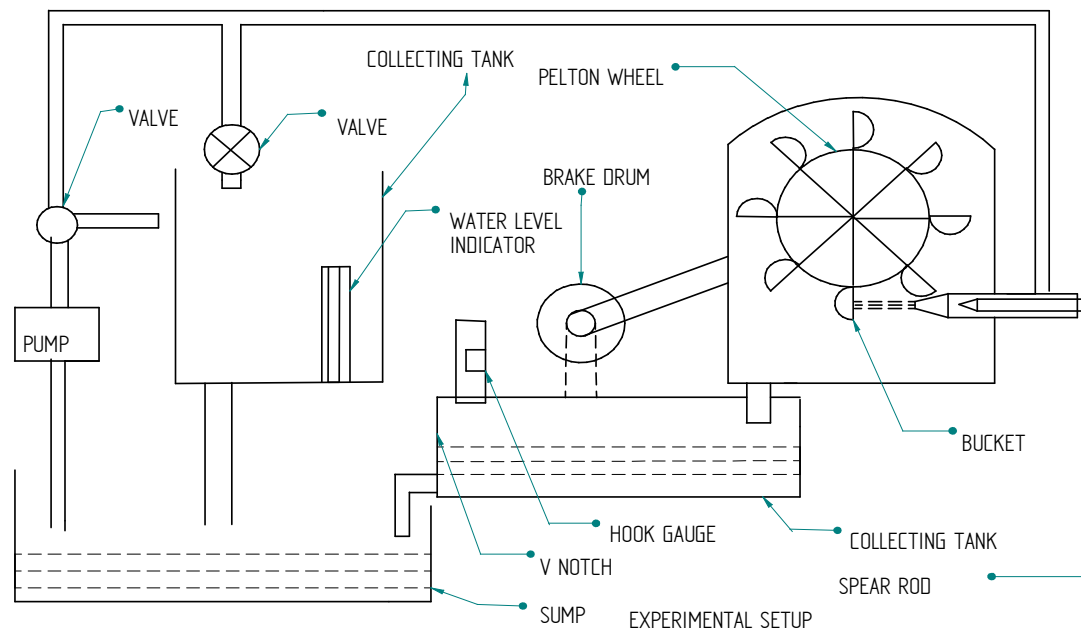

### A NOTE ON THE DESIGN OF PELTON TURBINE

#### DATA:

- \* Maximum head available on turbine(H) = 50 m
- \* Maximum flow rate available through runner(Q) =  $0.005 \text{ m}^3 / \text{s}$
- \* Runner Diameter (D) = 0.31 m
- \* Number of Buckets = 20 no's

#### APPARATUS:

- a) Centrifugal pump set, sump tank, notch tank, turbine, piping to operate the turbine on closed circuit water circulating system
- b) Digital RPM indicator, pressure gauge, flow control valve, mechanical loading with Spring balance

**Experiment No. 08****PELTON TURBINE TEST RIG**

(MECHANICAL BRAKEDRUM LOADING)

**AIM:**

- 1) To study the working principle of Pelton (impulse) turbine
- 2) To understand the functional aspects of various components constituting the turbine
- 3) To study performance characteristics of turbine at various heads, speed and load.

**INTRODUCTION:**

Hydraulic (or water) Turbines are the machines, which use the energy of water (Hydro –power) and convert it into Mechanical energy. Thus the turbine becomes the prime mover to run the electrical generators to produce the electricity, viz., hydroelectric power.

The Turbines are classified as impulse & reaction types. In impulse turbine, the head of water is completely converted into a jet, which impinges on the turbine runner, it is the pressure of the flowing water, which rotates the runner of the turbine. Of many types of turbines, the Pelton turbine, most commonly used, falls into the category of impulse turbine while the Francis & Kaplan falls into the category of reaction turbines.

Normally, Pelton turbine (impulse) requires high heads and low discharge, while the Francis & Kaplan (reaction turbines) require relatively low heads and high discharge. These corresponding heads and discharges are difficult to create in laboratory size turbine as the limitation of the pump's availability in the market. Nevertheless, at least the performance characteristics could be obtained within the limited facility available in the laboratories. Further, understanding various elements associated with any particular turbine is possible with this kind of facility.

**DESCRIPTION:**

The experimental setup consists of Centrifugal pump set, Turbine unit, sump tank, notch tank arranged in such a way that the whole unit works as recirculation water system. The centrifugal pump set supplies the water from the sump tank to turbine through control valve situated on the pump and a sphere valve before entering the turbine. The water after passing through the Turbine unit enters the Notch tank and then flows back to sump tank through the Notch tank which is fixed with a notch plate for measurement of flow rate.

The loading of the turbine is achieved by a brake drum with rope & spring balance, provision for measurement of turbine speed (digital RPM indicator), Head on turbine (pressure gauge) are built in on the control panel.

**SPECIFICATION:**

Supply pump capacity : 7.5Hp, 3ph, 440V  
 Turbine capacity : 1.1 kW  
 Run away speed : 1500 rpm  
 Loading : Brake drum with spring balance

**OBSERVATION TABLE:**

Constant Speed:

Sl No	Turbine speed 'N' rpm	Pr Gauge reading 'P' Kg/cm <sup>2</sup>	Head over turbine 'H' in m	Head over the notch $h_2-h_1=h$ in m	Spring balance reading Kg	Flow rate 'Q' m <sup>3</sup> /s	Input power kW	Brake power Bp kW	Turbine efficiency % $\eta_{\text{turb}}$
					$S_2-S_1= S$				

**PROCEDURE:**

- 1) Connect the panel to the electrical source & ascertain the direction of the pump is in order (clock wise direction from shaft end) by momentarily starting the pump.
- 2) Fill filtered clear water into the sump tank up to  $\frac{3}{4}$ <sup>th</sup> its full capacity
- 3) Keep the control valve situated above the pump in fully closed position, and the sphere valve in half open position.
- 4) Start the pump; gradually open the control valve slowly so that the turbine achieves sufficient speed.
- 5) Wait till the speed of the turbine maintained constant.
- 6) Load the turbine by turning the hand wheel situated on the load frame clock wise observing the dial spring balance to any desired minimum load
- 7) Allow the turbine speed to stabilize
- 8) Record the readings indicated on pressure gauge, dial balance RPM indicator and head over the notch plate
- 9) Continue loading the turbine in steps up to its full load and record the corresponding readings at each steps
- 10) After the experiment is over bring the turbine to no load condition by rotating the hand wheel on the load frame in anti clock wise direction and stop the pump.
- 11) Tabulate all the recorded readings and calculate the input power, output power & efficiency of the Turbine.

**Graphs to be plotted:****Main Characteristics Curves (constant Head)**

1.  $Q_u$  Vs  $N_u$
2.  $P_u$  Vs  $N_u$
3.  $\eta_o$  Vs  $N_u$

**Operating Characteristics Curves (Constant Speed)**

4.  $\eta_o$  Vs % full load.



Constant Head:

Sl No	Turbine speed 'N' rpm	Pr Gauge reading 'P' Kg/cm <sup>2</sup>	Head over turbine 'H' meters	Head over the notch h <sub>2</sub> -h <sub>1</sub> =h meters	Spring balanced reading Kg	Flow rate 'Q' m <sup>3</sup> /s	Input power kW	Brake power Bp kW	Turbine efficiency % $\eta_{\text{turb}}$
					S <sub>2</sub> -S <sub>1</sub> = S				

**CALCULATIONS:**

1. Head on turbine H:

$$H = 10 \times P \text{ where } P \text{ is the pressure gauge reading in Kg/cm}^2$$

$$\begin{aligned}
 2. \text{ Flow rate of water, } Q &= \frac{2}{3} C_d b \sqrt{2g} h^{3/2} \quad \text{m}^3/\text{sec} \\
 g &= 9.81 \text{ m/sec}^2 \\
 C_d &= 0.9 \\
 b &= \text{Width of notch in m} \\
 h &= \text{Head over the notch in m}
 \end{aligned}$$

3. Input power = WQH / 1000 kW where W = 9810 N/m<sup>3</sup>

4. Brake power

$$BP = 2\pi N (S_2 - S_1) r \times 9.81 / 60 \times 1000 \quad \text{kW}$$

$$\text{Where } r = \text{Radius of the brake drum} = 0.168 \text{ m} (0.152 + .016)$$

5. Turbine efficiency

$$\eta_{\text{turb}} = \text{BP} / \text{IP} \times 100$$

6. Unit speed,  $N_u = \frac{N}{\sqrt{H}}$

7. Unit discharge,  $Q_u = \frac{Q}{\sqrt{H}}$

8. Unit power,  $P_u = \frac{P_{\text{shaft}}}{H^2}$

9. Specific speed,  $N_s = \frac{N\sqrt{P_{\text{shaft}}}}{H^{\frac{5}{4}}}$

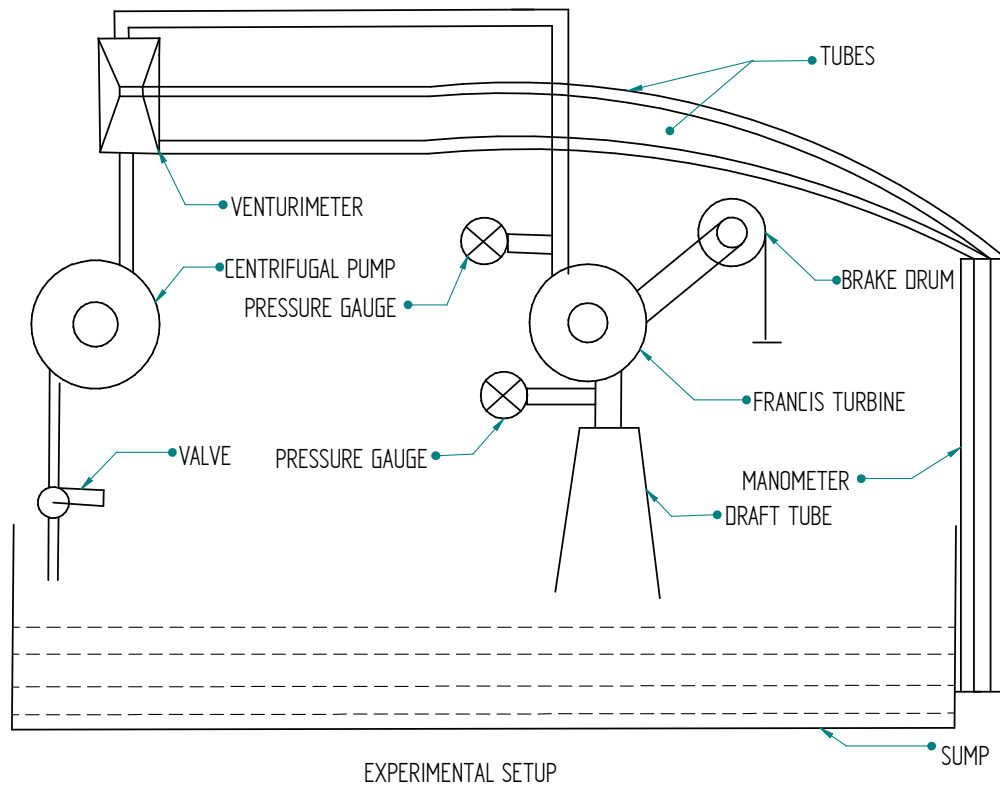

### **A NOTE ON THE SPECIFICATION OF FRANCIS TURBINE**

#### **Data:**

- \* Maximum head available on turbine (H) = 05- 09 m.
- \* Maximum flow rate available through Impeller (Q) =  $0.035 \text{ m}^3 / \text{s}$   
= 1200- 1500 lit / min
- \* Impeller Diameter (D) = 150 mm
- \* Number of Guide vanes = 8 No's (adjustable)

#### **Apparatus:**

- c) Centrifugal pump set, sump tank, turbine, piping system with Venturimeter to operate the Turbine on closed circuit water circulating system.
- d) Digital RPM indicator, Digital Voltmeter, Ammeter, pressure gauge, flow control valve, with suitable electrical dynamometer loading with resistance bank (heaters), with switches, fan to decipate heat.

**Experiment No. 09****FRANCIS TURBINE TEST RIG  
(USING VENTURIMETER)****INTRODUCTION:**

Hydraulic (water) Turbines are the machines, which use the energy of water (Hydro –power) and convert it into Mechanical energy, which is further converted into electrical energy. Thus the turbine becomes the prime mover to run the electrical generators to produce electricity (Hydroelectric power).

The Turbines are classified as impulse & reaction types. In impulse turbine, the head of water is completely converted into a jet, which exerts the force on the turbine; it is the pressure of the flowing water, which rotates the Impeller of the turbine. Of many types of turbine, the Pelton wheel, most commonly used, falls into the category of impulse turbine, while the Francis & Kaplan falls into the category of reaction turbines.

Normally, Pelton wheel (impulse turbine) requires high heads and low discharge, while the Francis & Kaplan (reaction turbines) require relatively low heads and high discharge. These corresponding heads and discharges are difficult to create in laboratory because of the limitation of required head & discharges. Nevertheless, an attempt has been made to study the performance characteristics within the limited facility available in the laboratories. Further, understanding various elements associated with any particular turbine is possible with this kind of facility.

**DESCRIPTION:**

While the impulse turbine is discussed elsewhere in standard textbooks, Francis turbine (reaction type) which is of present concern consists of main components such as Impeller (runner), scroll casing and draft tube. Between the scroll casing and the Impeller there are guide vanes, which guides the water on to the impeller thus rotating the Impeller shaft. There are eight guide vanes, which can be turned about their own axis so that the angle of inclination may be adjusted while the turbine is in motion. When guide vane angles are varied, high efficiency can be obtained over wide range of operating conditions.

The actual experiment facility supplied consists of a sump tank, centrifugal pump set, turbine unit and Venturimeter arranged in such a way that the whole unit works on recirculating water system. The centrifugal pump set supplies the water from the sump tank to the turbine through control valve (Gate valve). The water from the pump passes through a Venturimeter (for measurement of discharge) to the turbine unit enters the sump tank through the draft tube.

The loading of the turbine is achieved by electrical dynamometer coupled to the turbine through a V-Belt drive (V grooved pulley). The control panel is equipped with a set of heaters (electrical resistance) in steps of 200Vats each, 10 No. (200 x 10 Total 2Kw) with individual switches are provided for loading the electrical dynamometer (in turn loading the turbine). The provisions for measurement of load (by digital Voltmeter & Ammeter), turbine speed (digital RPM indicator),

differential pressure across Venturimeter (Double column Mercury Manometer) & total head on turbine (pressure & vacuum gauge).

**Specification:**

Supply pump capacity : 7.5 Kw (10 Hp) 3ph, 400V

Turbine capacity : 2.6 HP (2 Kw)

Run away speed : 2000 RPM

**TABULAR COLUMN**

**Constant Speed:**

Sl No	Pressure Gauge reading 'P' Kg/cm <sup>2</sup>	Head over the turbine 'H' in m	Presser Gauge reading in Kg/cm <sup>2</sup> Across Venturimeter		$\Delta h$	Alternator		Flow rate 'Q' m <sup>3</sup> /s	Input power Kw (Ip)	Out put power Kw (Op)	Turbine efficiency % $\eta_{turb}$
			h <sub>1</sub>	h <sub>2</sub>		V volts	I amps				

Procedure:

- 1) Install the equipment near a 3 phase 440 volts, 50 Hz, 20 amps power source & water source.
- 2) Connect the panel to the electrical source & ascertain the direction of the pump is in order (clock wise direction from shaft end) by momentarily starting the pump.
- 3) Fill filtered clear water into the sump tank up to  $\frac{3}{4}$ <sup>th</sup> its full capacity.
- 4) Keep the gate valve situated above the pump in fully closed position, turbine guide vanes in full open position.
- 5) Start the pump, gradually open the gate valve slowly so that the turbine achieves sufficient speed to generate 200 volts on the panel voltmeter.
- 6) Wait till the speed of the turbine & generated voltage maintained constant.
- 7) Put on the first electrical load switch and adjust the speed of Turbine to 200V on the panel Voltmeter and record the corresponding Ammeter, Pressure gauge & Head over the notch readings.
- 8) Continue increasing the load on the Turbine step by step by switching ON the consecutive load switches one by one, by gradually opening the Gate valve so that the Voltmeter reading shows 200V on each step. Record the corresponding readings of Ammeter, Pressure Gauge & Head over the notch.
- 9) Change the Turbine guide vane to any desired position (between fully open to closed conditions) by operating the hand wheel situated at the rear end of the Turbine to repeat the experiment on varied condition by following steps 7 & 8.
- 10) After the experiment is over bring the turbine to no load condition by switching OFF the load switches one by one and simultaneously closing the Gate valve (care must be taken to avoid sudden increase in speed / Volts while switching 'off' the load switches) & stop the pump.
- 11) Tabulate all the recorded readings and calculate the input power, output power & efficiency of the Turbine.

Note: Drain all the water from the sump tank, refill with fresh clean water once in a month. When the equipment is not in use for a longer duration, drain all water from the sump tank keep it clean & dry.

**Graphs to be plotted:****Main Characteristics Curves (constant Head)**

1.  $Q_u$  Vs  $N_u$
2.  $P_u$  Vs  $N_u$
3.  $\eta_o$  Vs  $N_u$

**Operating Characteristics Curves (Constant Speed)**

4.  $\eta_o$  Vs % full load.

**Constant Head:**

Sl No	Pressure Gauge reading 'P' Kg/cm <sup>2</sup>	Head over the turbine 'H' in m	Presser Gauge reading in Kg/cm <sup>2</sup> Across Venturimeter		$\Delta h$	Alternator		Flow rate 'Q' m <sup>3</sup> /s	Input power Kw (Ip)	Out put power Kw (Op)	Turbine efficiency % $\eta_{turb}$
			h <sub>1</sub>	h <sub>2</sub>		V volts	I amps				

**CALCULATION**

Out put power       $Op = \frac{V \times I}{1000 \times \eta_{Gen}}$        $\eta_{Gen} = 0.75$

Input power       $Ip = \frac{W Q H}{1000}$       where:  $w = 9810 \text{ n/m}^3$

$Q = C_d k \sqrt{2 g h w}$        $K = \frac{a_1 a_2}{\sqrt{a_1^2 - a_2^2}}$

$C_d = 0.94$

Turbine efficiency  $\eta_{Tur} = \frac{\text{Out put power}}{\text{Input power}} \times 100 \%$

Unit speed,  $N_u = \frac{N}{\sqrt{H}}$

Unit discharge  $Q_u = \frac{Q}{\sqrt{H}}$

$$\text{Unit power, } P_u = \frac{P_{\text{shaft}}}{H^2}$$

$$\text{Specific speed, } N_s = \frac{N\sqrt{P_{\text{shaft}}}}{H^{\frac{5}{4}}}$$



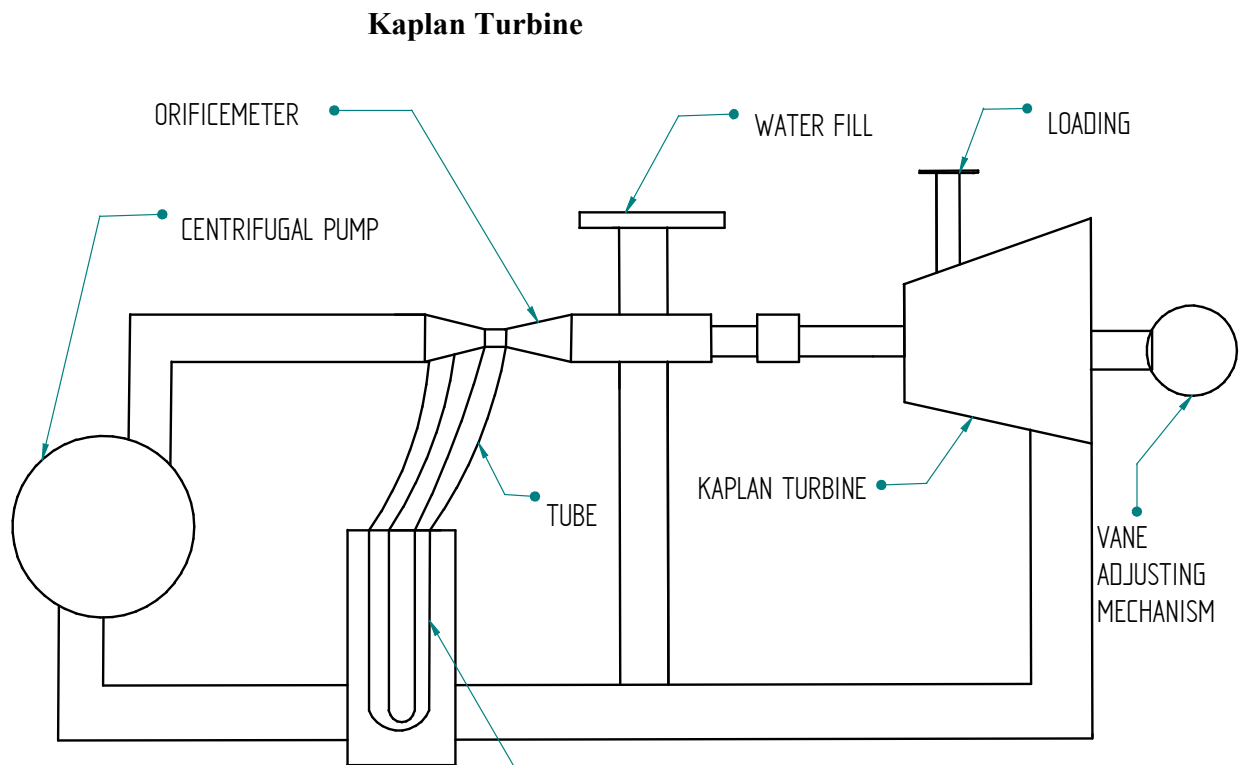

**A NOTE ON THE SPECIFICATION OF KAPLAN TURBINE**

**DATA:**

- \* Maximum head available on turbine(H) = 9 - 12 m.
- \* Maximum flow rate available through runner(Q) =  $0.05 \text{ m}^3 / \text{s}$   
= 3000 lit / min
- \* Propeller Diameter (D) = 150 mm
- \* Number of Propeller Blades = 4 No's (adjustable)
- \* Hub Diameter (d) = 60 mm

**APPARATUS:**

- a. Centrifugal pump set, sump tank, turbine, piping system to operate the Turbine on closed circuit water circulating system
- b. Digital RPM indicator, pressure gauge, flow control valve, with suitable electrical dynamometer loading with resistance bank (heaters), switches, fan to dissipate heat from the resistance (heaters) load

**Experiment No. 10****KAPLAN TURBINE TEST RIG**

(USING ORFICE METER)

**AIM:**

1. To study the working principle of Kaplan (reaction) turbine.
  2. To understand the functional aspects of various components constituting the turbine.
- To study performance characteristics of turbine at various heads, flow rates and speeds

**INTRODUCTION:**

Hydraulic (water) Turbines are the machines, which use the energy of water (Hydro –power) and convert it into Mechanical energy, which is further converted into electrical energy. Thus the turbine becomes the primover to run the electrical generators to produce electricity (Hydroelectric power).

The Turbines are classified as impulse & reaction types. In impulse turbine, the head of water is completely converted into a jet, which exerts the force on the turbine; it is the pressure of the flowing water, which rotates the runner of the turbine. Of many types of turbine, the Pelton wheel, most commonly used, falls into the category of impulse turbine, while the Francis & Kaplan falls into the category of reaction turbines.

Normally, Pelton wheel (impulse turbine) requires high heads and low discharge, while the Francis & Kaplan (reaction turbines) require relatively low heads and high discharge. These corresponding heads and discharges are difficult to create in laboratory because of the limitation of required head & discharges. Nevertheless, an attempt has been made to study the performance characteristics within the limited facility available in the laboratories. Further, understanding various elements associated with any particular turbine is possible with this kind of facility.

**DESCRIPTION:**

While the impulse turbine is discussed elsewhere in standard textbooks, Kaplan turbine (reaction type) which is of present concern consists of main components such as propeller (runner), scroll casing and draft tube. Between the scroll casing and the runner, the water turns through right angle into axial direction and passes over the runner and thus rotating the runner shaft. The runner has four blades, which can be turned about their own axis so that the angle of inclination may be adjusted while the turbine is in motion. The runner blade angles can be varied to obtain higher efficiency over wide range of operating conditions. In other words even at part loads, when a low discharge is flowing over the runner, a high efficiency can be attained in case of Kaplan turbine. Where as this provision does not exist in Francis & Propeller turbines where the runner blade angles are fixed and integral with the hub.

The actual experimental setup consist of a centrifugal pump set, turbine unit, sump tank, arranged in such a way that the whole unit works on recirculating water system. The centrifugal pump set

**Specification:**

Supply pump capacity : 7.5 Kw (10 Hp) 3ph, 400V

Turbine capacity : 2.6 HP (2 Kw)

Run away speed : 2000 RPM

**OBSERVATION TABLE****CONSTANT SPEED:**

Sl No	Turbine speed 'N' rpm	Pr Gauge reading 'P' Kg/cm <sup>2</sup>	Head over turbine 'H' in m	Manometer reading		Load		Flow rate 'Q' m <sup>3</sup> /s	Input power kW	Brake power Bp kW	Turbine efficiency % $\eta_{\text{turb}}$
				L <sub>1</sub>	L <sub>2</sub>	Voltage V Volts	Current I Amps				
1											
2											
3											
4											
5											

**CONSTANT HEAD:**

Sl No	Turbine speed 'N' rpm	Pr Gauge reading 'P' Kg/cm <sup>2</sup>	Head over turbine 'H' meters	Manometer reading		Load		Flow rate 'Q' m <sup>3</sup> /s	Input power kW	Brake power Bp kW	Turbine efficiency % $\eta_{\text{turb}}$
				L <sub>1</sub>	L <sub>2</sub>	Voltage V Volts	Current I Amps				
1											
2											
3											
4											
5											

supplies the water from the sump tank to the turbine through control valve (Butterfly valve) and passes through an orifice meter connected to a double column mercury manometer which facilitates to obtain the quantity of water discharged from the turbine unit. Water after passing through the turbine unit enters the sump tank through the draft tube.

The loading of the turbine is achieved by electrical dynamometer coupled to the turbine through a V- Belt drive (V grooved pulley). A set of heaters (electrical resistance) in steps of 200 Watts each, 10 no. (Total 2Kw) with individual switches provided for loading the electrical dynamometer (in turn loading the turbine). The provisions for measurement of turbine speed (digital RPM indicator), head on turbine (pressure gauge) are built-in on the control panel.

### **OPERATING PROCEDURE:**

Install the equipment near a 3 phase 440 volts, 50 Hz, 20 amps power source & water source.

1. Connect the panel to the electrical source & ascertain the direction of the pump is in order (clock wise direction from shaft end) by momentarily starting the pump.
2. Fill filtered clear water into the sump tank & discharge tank upto the flow channel level.
3. Keep the butterfly valve situated above the pump in partially closed position & turbine runner blade in full open position.
4. Start the pump, gradually open / close the butterfly valve so that the turbine achieves sufficient speed to generate 220volts on the panel voltmeter
5. Wait till the speed of the turbine & generated voltage maintained constant.
6. Open all the valves provided on the manometer fully and the valves across the orifice meter partially to release the air trapped in the manometer and observe water flowing through the air vent tubes.
7. Close both the air vent valves simultaneously and read the difference of mercury level in the manometer limbs to obtain the discharge.
8. Switch "ON" the first two electrical load switches and adjust the speed of Turbine to 220V on the panel Voltmeter by adjusting the flow control valve and record the corresponding Ammeter, Pressure gauge and manometer readings.
9. Continue increasing the load on the Turbine step by step by switching "ON" the consecutive load switches in sets of two and maintain the panel voltmeter reading at 220V by adjusting the flow control valve accordingly.
10. Record the relative voltmeter, ammeter, pressure gauge and manometer readings on each step.
11. Bring the Turbine to no load condition by switching OFF the load switches in steps.
12. Change the Turbine Runner position by operating the hand wheel situated at the rear end of the Turbine & repeat the experiment following the steps 10 to 12.
13. After the experiment is over bring the turbine to no load condition & stop the pump.
14. Tabulate all the recorded readings and calculate the output power, input power & efficiency of the Turbine.

**CALCULATIONS:**

1. Head on turbine H :

$$H = 10 \times P \quad \text{where } P \text{ is the pressure gauge reading in Kg/cm}^2$$

$$\text{Flow rate of water } Q = \frac{C_d \times a_1 \times a_2}{\sqrt{a_1^2 - a_2^2}} \times \sqrt{2gh} \quad \text{m}^3/\text{s}$$

$$\text{Where } g = 9.81 \text{ m/s}^2$$

$$C_d = 0.62$$

$$a_1 =$$

$$a_2 =$$

$$h = (l_2 - l_1) \times 12.6 \text{ m.}$$

$$\text{Where } \frac{\rho_{hg} - \rho_w}{\rho_w} \times (l_2 - l_1) \text{ m}$$

2. Input power (Hydraulic power input to Turbine)

$$I_p = \frac{WQH}{1000} \quad \text{Kw} \quad \text{where } W = 9810 \text{ N/m}^3$$

3. Output power

$$O_p = \frac{V \times I}{1000 \times \eta_{gen}} \quad \text{Kw} \quad \text{Where } \eta_{gen} = 0.7$$

4. % Turbine efficiency

$$\eta_{turb} = \frac{\text{Output power}}{\text{Input power}} \times 100$$

$$\text{Unit speed, } N_u = \frac{N}{\sqrt{H}}$$

$$\text{Unit discharge } Q_u = \frac{Q}{\sqrt{H}}$$

$$\text{Unit power, } P_u = \frac{P_{shaft}}{H^2} \quad \text{Specific speed, } N_s = \frac{N \sqrt{P_{shaft}}}{H^{\frac{5}{4}}}$$

**Graphs to be plotted:****Main Characteristics Curves (constant Head)**

1.  $Q_u$  Vs  $N_u$
2.  $P_u$  Vs  $N_u$
3.  $\eta_o$  Vs  $N_u$

**Operating Characteristics Curves (Constant Speed)**

4.  $\eta_o$  Vs % full load.

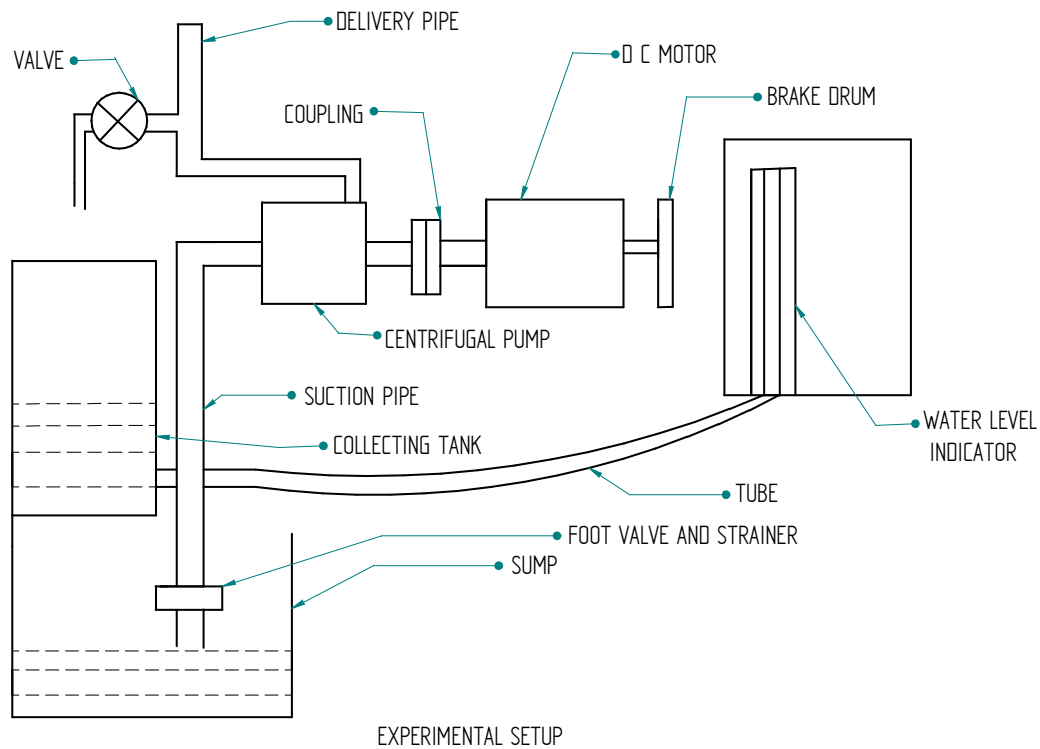

### SPECIFICATIONS:

**Single stage pump with Motor**

**Sump tank:**

MOC: Stainless Steel,

**Measuring tank:**

MOC: Stainless Steel

Area of cross section:  $0.125 \text{ m}^2$  (Measuring tank)

**Drive Belt Size:** - A-26

**Experiment No. 11****SINGLE STAGE CENTRIFUGAL PUMP**

**AIM:** To conduct performance test on a Single stage Centrifugal pump test rig.

**INTRODUCTION:**

A pump may be defined as mechanical device when interposed in a pipe line, converts the mechanical energy supplied to it from an external source into hydraulic energy, thus resulting in the flow of liquid from lower potential to higher potential.

The pumps are of major concern to most engineers and technicians. The types of pumps vary in principle and design. The selection of the pump for any particular application is to be done by understanding their characteristics. The most commonly used pumps for domestic, agricultural and industrial are Centrifugal, axial flow, reciprocating, air jet, and diaphragm and turbine pumps. Most of these pumps fall into the main class namely Rotodynamic, Reciprocating (positive displacement) and Fluid operated pumps.

**THEORY:**

The principle of operation of a single stage centrifugal pump is covered under Rotodynamic pump category. In this pump, the liquid is made to rotate in a closed volute chamber. Thus creating the centrifugal action, which gradually builds the pressure gradient towards outlet resulting in a continuous flow.

These pumps are of simple construction can be directly coupled to electric motor and more suitable for handling clear, semi viscous, as well as turbid liquids. The hydraulic head per stage at low flow rates is limited and hence not suitable for high heads, in case of single stage centrifugal pumps. But as the pump in this case in a multi stage construction the pressure gradually builds up in successive stages almost equally in each stage. Thus achieving considerably higher heads. The multi stage centrifugal pump test rig allows the students to understand and study the various characteristics and pressure build up pattern in individual stages.

**DESCRIPTION:**

The single stage Centrifugal pump test rig mainly consists of:

- a) Single stage Centrifugal pump
- b) AC Drive motor of suitable capacity coupled to pump by stepped pulley arrangement.
- c) SS sump tank and measuring tank with a piezometer
- d) G. I. Pipe connections with necessary control valve etc... mounted on a neatly painted M.S. structure. The panel board is equipped with an energy meter for measurement of power input to the motor, a digital RPM indicator to indicate the speed of the pump/motor, a Vacuum gauge to measure suction head, & pressure gauge for measurement of delivery head, a starter of suitable capacity, indicating lamps and fuse etc.



**CALCULATIONS:**

- **Basic data / constants:**

$$\begin{aligned}
 1 \text{ kg / cm}^2 &= 760 \text{ mm Hg (10 m of water)} \\
 \text{Density of water} &= 1000 \text{ kg / m}^3 \text{ ( 9810 N / m}^3 \text{ )} \\
 \text{Area of collecting tank} &= 0.125 \text{ m}^2
 \end{aligned}$$

- **Discharge rate “ Q ” in m<sup>3</sup> / s**

$$Q = \frac{A \times h}{t}$$

where ‘h’ is height of water collected in measuring tank for a time interval of ‘t’ sec.

- **Total head “ H ” in m**

$$\begin{aligned}
 H &= 10(\text{Delivery Pressure} + \text{Vacuum head}) \\
 &= 10(P + P_v) \\
 \text{where } P &\text{ is pressure in kg / cm}^2, P_v \text{ is the Vacuum in mm of Hg} \\
 p &= (1.032 + \text{pressure reading}) \quad P_v = (1.032 - (\text{suction pressure reading} \times 1.33 \times 10^{-3}))
 \end{aligned}$$

- **Power input to motor (kW)**

**Data:** Energy meter constant E.M.C. = 3200 Rev/kw-h

$$\text{I.P} = \frac{K}{\text{E.M.C.}} \times \frac{60 \times 60}{t} \times \eta_{\text{motor}} = \text{kW.}$$

$$\text{Where } \eta_{\text{motor}} = 0.70, (70 \%)$$

Where ‘K’ is the number of revolutions energy meter disc = 10 rev

‘t’ is the time taken in seconds by the Energy Meter for K revolutions

‘ $\eta_m$ ’ = motor efficiency 0.70 (70%)

(1hp = 0.736 kW)

(1 kW = 1.36 hp.)

- **Output Power ( delivered by the pump) kW**

$$= \frac{W \times Q \times H}{1000} \text{ kW}$$

Where W is 9810 N/m<sup>3</sup>

$$\% \eta_{\text{pump}} = \frac{\text{Out power} \times 100}{\text{Input power}} \quad \text{Q is Discharge}$$

**Table of readings:**

Speed N (rpm)	Delivery pressure p (kgf/cm <sup>2</sup> )	Suction pressure P <sub>v</sub> mm of Hg	Time taken for 10 Impulse of energy meter (t <sub>e</sub> ) s	Water level rise in tank R		Discharge time t (s)
				mm	m	

**Table of calculations:**

Speed of pump N (rpm)	Head H m of water	Discharge Q (m <sup>3</sup> /s)	Power input to pump P <sub>in</sub> (kW)	Power developed by pump P <sub>p</sub> (kW)	Overall efficiency η <sub>o</sub> (%)

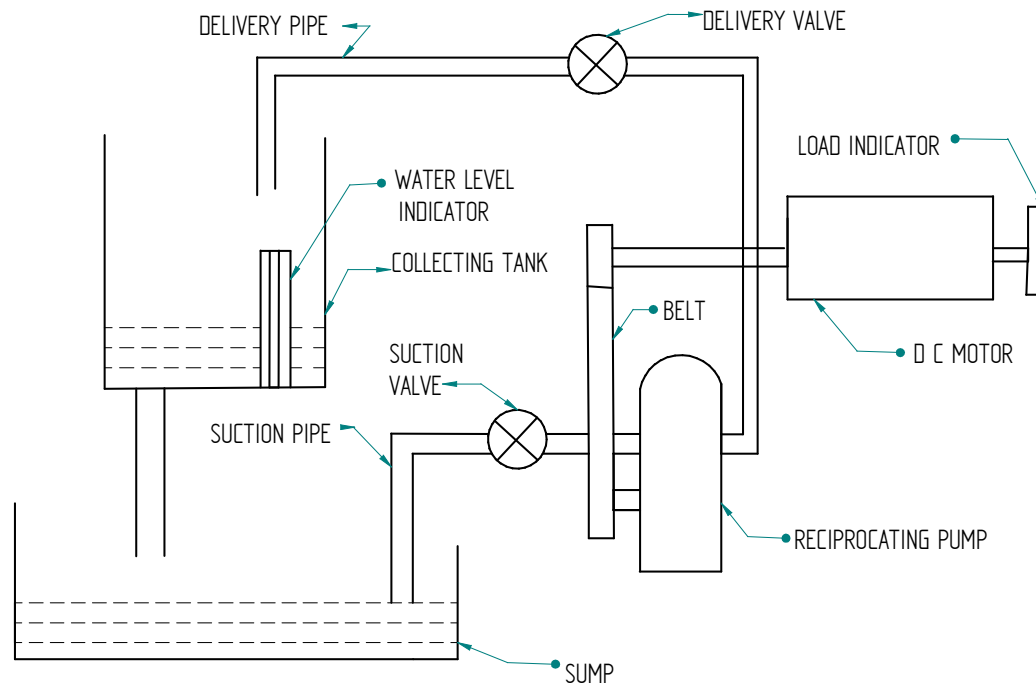

EXPERIMENTAL SETUP

**CALCULATIONS:**

- Basic data / constants:

$$\begin{aligned}
 1\text{kg/cm}^2 &= 760 \text{ mm Hg (10 m of water)} \\
 \text{Density of water} &= 1000 \text{ kg / m}^3 \\
 \text{Area of collecting tank} &= 0.125 \text{ m}^2
 \end{aligned}$$

- Discharge rate “ Q ” in  $\text{m}^3 / \text{s}$

$$Q = \frac{A \times h}{t}$$

where ‘h’ is height of water collected in measuring tank for a time interval of ‘t’ sec.

- Total head “ H ” in m

$$\begin{aligned}
 P_D &= 1.032 + \text{Reading} \\
 P_V &= 1.032 - (\text{Reading} \times 1.315 \times 10^{-3})
 \end{aligned}$$

$$\begin{aligned}
 H &= 10 (\text{Delivery Pressure} + \text{Vacuum head}) \\
 &= 10 (P_D + P_V)
 \end{aligned}$$

where  $P_D$  is pressure in  $\text{kg / cm}^2$ ,  $P_V$  is the Vacuum in mm of Hg

**Experiment No. 12****RECIPROCATING PUMP TEST RIG****AIM:**

To study the performance and characteristics of reciprocating pump and to determine the efficiency of the pump

**INTRODUCTION:**

In general, a pump may be defined as mechanical device when connected in a pipe line, can convert the mechanical energy into hydraulic energy, thus resulting in the flow of liquid from lower potential to higher potential.

The pumps are of major concern to most engineers and technicians. The types of pumps vary in principle and design. The selection of the pump for any particular application is to be done by understanding their characteristics. The most commonly used pumps for domestic, agricultural and industrial are Centrifugal, axial flow (stage pumps), reciprocating, air jet, and diaphragm and turbine pumps. These pumps fall mainly into a category of rotodynamic, reciprocating (positive displacement) and fluid operated pumps.

**THEORY:**

Reciprocating pump is a positive displacement pump. It mainly consists of a piston reciprocating inside a cylinder thus performing suction and delivery strokes. The cylinder is alternately filled and emptied by forcing and drawing the liquid by mechanical motion. This type is called positive type. Delivery and suction pipes are connected to a cylinder. Each of the two pipes is provided with a non-return valve. The function of which is to ensure unidirectional flow of liquid. It generally operates at low speed and is therefore to be coupled to a motor with V-belt. It is stable for small discharge and high heads. Generally these pumps are used for feeding small boilers, for lifting water to a higher heads & for pumping light oil. The present test rig allows the students to understand and draw the operating characteristics at various heads, flow rates and speeds.

**DISCRIPTION:**

The Reciprocating pump test rig mainly consists of:

- a) Double stroke Reciprocating pump
- b) AC Drive motor of suitable capacity coupled with a belt drive Variable speed stepped cone pulley.
- c) SS sump tank, SS measuring tank with a piezometer
- d) G. I. Pipe connections with necessary control valve etc... mounted on a neatly painted M.S. structure.
- e) The panel board is equipped with an energy meter for measurement of power input to the motor, a digital RPM indicator to indicate the speed of the pump, a Vacuum gauge to measure suction head, a pressure gauges for measurement of delivery head. a three phase starter of suitable capacity, main indicating lamps and fuses.

INPUT POWER (I<sub>p</sub>):

Data:

Energy meter constant E.M.C.= 1600 Imp / kw / h

$$(I_p) = \frac{n}{K} \times \frac{60 \times 60}{t} \times \eta_m$$

where 'n' is the number of impulse of energy meter

't' is the time taken in seconds by the Energy Meter for n impulses

'η<sub>m</sub>' = motor efficiency 0.72 (72%)

- Output Power ( delivered by the pump)

$$= \frac{W \times Q \times H}{1000}$$

where W is 9180 N/m<sup>3</sup>

$$\% \eta_{\text{overall}} = \frac{\text{Output power}}{\text{Input power}} \times 100$$

TABULAR COLUMN :

Drive Belt Size- B-53.

Sl. No.	Speed of pump in rpm	Suction pressure 'P <sub>v</sub> ' (mm of Hg)	Delivery pressure 'P' Kg/cm <sup>2</sup>	Energy meter reading for 10 pulses. 't' in sec's	10 cm raise of water level in collecting tank 'T' in sec's
1.					
2.					
3.					
4.					

Calculated readings:

Sl.No.	I.p. (kW)	Discharge 'Q' m <sup>3</sup> / Sec	Head 'H' in mts of water	O.p.= $\frac{WQH}{1000}$ (kW)	%η = $\frac{Op}{Ip} \times 100$
1					
2					

**Procedure:**

1. Connect the power cable to three phase, 440 volts, 10 Amps with earth connection
2. Fill water in air vessel.
3. Keep the delivery valve fully open.
4. Fill the sump tank with clean soft water.
5. Select the desired speed by adjusting the step cone pulley - motor base handle.
6. Switch on the mains, the mains on indicators glow, now switch on the pump, water starts flowing to the measuring tank.
7. Note down the pressure gauge, vacuum gauge reading and time for number of revolutions of energy meter disc at full opening of delivery valve.
8. Operate the butterfly valve to note down the collecting tank reading against the known time, and keep it open when the readings are not taken.
9. Repeat the experiment for different openings of delivery valve and note down the readings as above
10. Repeat the experiment for different speeds and repeat the steps from 5 to 8.
11. Tabulate the readings.
12. After the experiment is over switch off the mains and keep the delivery valves fully open.
13. Calculate the efficiency of the pump.

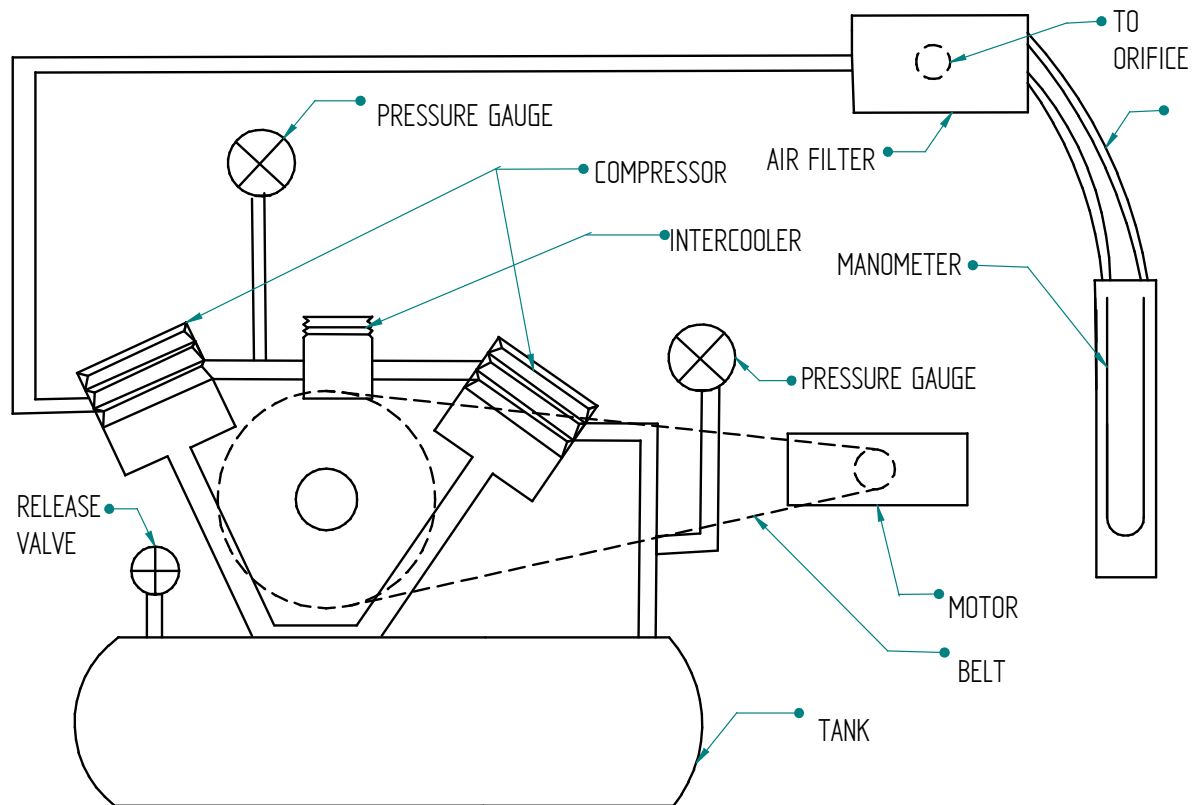

EXPERIMENTAL SETUP

**SPECIFICATION:**

Type	:	Two Stage two Cylinders with Inter Cooler.
Motor	:	3HP AC.
Max. Working Pressure:	:	07 kg / cm <sup>2</sup>
Cylinder Bore	:	LP Cylinder: 70 mm dia HP Cylinder: 50 mm dia.
Stroke	:	85 mm

**Experiment No. 13****RECIPROCATING AIR COMPRESSOR TEST RIG  
(TWO STAGE)****AIM OF THE EXPERIMENT:**

- a) To study the working of two Stage Reciprocating Air Compressor.
- b) Determination of Volumetric Efficiency.

**INTRODUCTION:**

Compressed Air is a form of Energy used extensively for such operations as Pneumatic Machines & Tools, Material Handling, Construction, Mining, etc. Compressor is a device used to compress air to a pressure higher than the atmosphere. Generally, Compressors fall into any of the following categories namely reciprocating and rotary Compressor.

This Manual describes the Working of the two Stage Reciprocating Air Compressor and its performance.

**Procedure:**

- 1) Release all the air from the tank and close the outlet valve.
- 2) Ascertain sufficient measuring fluid in U tube manometer.
- 3) Switch – ON the mains and observe the indicators glow.
- 4) Keep the outlet valve closed.
- 5) Switch – ON the starter and run the compresses.
- 6) Open the valves provided on LP and HP Cylinders Connected to the respective pressure gauges on the panel in such a way that the fluctuation of the needle is arrested.
- 7) Maintain the pressure at  $1 \text{ Kg / cm}^2$  by adjusting the outlet valve and record the following readings: manometer deference, time for n revolution of energy meter, temperatures at 1, 2, 3, & 4 position RPM, LP and HP gauge pressure.
- 8) Stop the compressor and release all the air form the tank.
- 9) Tabulate the readings and calculate volumetric efficiency.



**CALCULATION:**

**DATA:**

- Density of air  $\rho_a$  = 1.293 kg/m<sup>3</sup>
- Density of water  $\rho_w$  = 1000 kg/m<sup>3</sup>
- Acceleration due to Gravity = 9.81 m / s<sup>2</sup>
- Orifice Diameter = 15 mm.
- Co-efficient of Discharge of Orifice = 0.62

Volumetric Efficiency,

$$\% \eta_{vol} = \frac{V_a}{V_s} \times 100$$

Where:  $V_a$  is actual volume of air compressed

$$Q_{act} = V_a = C_d a_o \sqrt{2 g h_a} \quad \text{m}^3 / \text{sec}$$

$$a_o = \text{Area of Orifice} = (\pi / 4) d^2$$

$$d = \text{Dia of orifice} = 20 \text{ mm}$$

$$h_a = h_w \left[ \frac{\rho_w}{\rho_a} - 1 \right]$$

$$Q_{theo} = V_s = \text{swept volume}$$

$$= (\pi / 4) D^2 \times \text{Stroke length} \times \text{Compressor speed} / 60 \quad \text{m}^3 / \text{s}$$

$$D = \text{Bore Dia of Lp cylinder (70 mm or 0.07m)}$$

**OBSERVATIONS TABLE**

SI No	Pressure gauge reading		Time for 'η' Revolution of energy meter Disc in sec T	Manometer reading Across orifice in mm			Speed of compressor in RPM	Temperature			
	Stage Tank 1	Stage Tank 2		h <sub>1</sub> mm	h <sub>2</sub> mm	Δh = h <sub>2</sub> - h <sub>1</sub> m		T <sub>1</sub>	T <sub>2</sub>	T <sub>3</sub>	T <sub>4</sub>

Note: Temperature Points,

T<sub>1</sub> = Air Intel Temperature.

T<sub>2</sub> = After first stage

T<sub>3</sub> = After Intel Cooler.

T<sub>4</sub> = After Second Stage.

Orifice Dia =20 mm.

**TABLE OF CALCULATIONS:**

SI No	Discharge $Q_{act}$ $m^3 / s$	Discharge $Q_{Theo}$ $m^3 / s$	Volumetric Efficiency $\eta_{vol}$ %

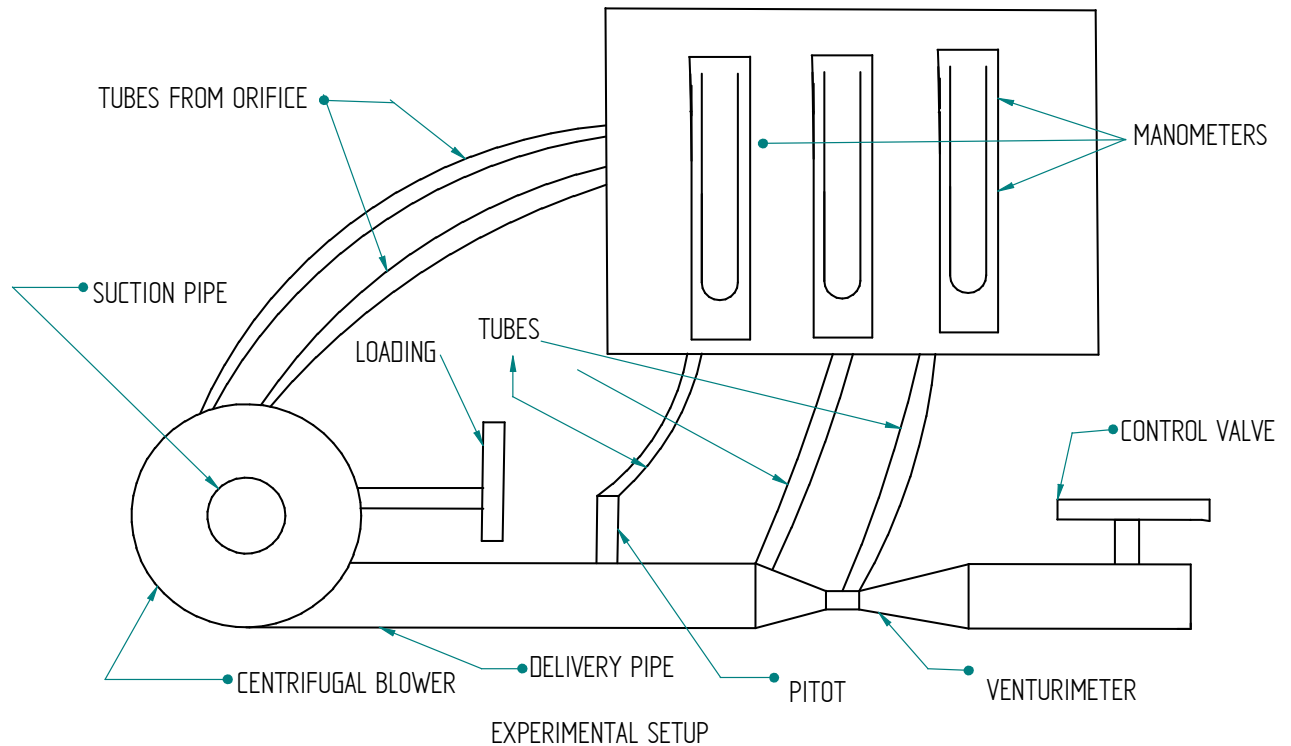

**CALCULATION**

**1 Discharge**

$$Q = A \times V \quad \text{m}^3/\text{s}$$

Where V = average of anemometer Readings  
 C.S Area of the duct = 0.12m<sup>2</sup>

**2. Input power of A/C Motor**

$$I_p = \frac{n \times 60 \times 60}{k \times t}$$

where : n = no of energy meter disc revolutions

k = energy meter constant  
 t= time taken for no of in sec

$$k = 3600 \text{ rev / kw-hr}$$

**Experiment No. 14****CENTRIFUGAL AIR BLOWER TEST RIG**

**AIM:** To study the performance of a centrifugal air blower at various operating conditions

**INTRODUCTION:**

The equipment has been designed as an experimental unit to study the performance characteristics of centrifugal Blower at various operating conditions. The test rig mainly consists of centrifugal blower handling air as the medium of flow and is driven by a foot mounted A.C. Motor. The test rig has provisions for varying the following parameters like discharge and impellers of the blower. Three interchangeable impellers (backward, forward, and straight) have also been supplied for studying the performances. These parameters have been used to draw the standard performance curves; covering the head Vs flow rate and Efficiency Vs flow rate at constant Speed.

**PROCEDURE:**

1. Connect the control panel input power cable to 3ph A.C.supply , with neutral and earth.
2. keep all the Switches /controls in Off position.
3. Switch On the mains and observe the 3ph light indicators glow.
4. Turn the rotary switch clock wise to put on the panel meters.
5. Ascertain sufficient measuring fluid (water) in manometers & the direction of rotation of the blower as indicated on the casing.
6. Keep the outlet butterfly valve fully open.
7. Switch on the starter so that the motor speed builds up to the rated rpm.
8. Keep the pitot tube half way above the center of the duct.
9. Record all the readings indicated by manometer, energy meter (Time for 2 rev) at valve full open position.
10. Change the valve to 60<sup>0</sup> position and record the all readings.
11. Similarly record the readings on 30<sup>0</sup> and fully closed positions.
12. Tabulate all the readings and calculate.
13. Repeat the experiment on different impellers
14. After the experiment switch off the motor and electrical mains.

**3. Output power of blower Op**

$$(\text{Op})_{\text{Blower}} = \frac{W_a \times Q \times H}{1000}$$

$$W_a = 12.65 \text{ N/m}^3$$

$$\rho_a = 1.29 \text{ kg/m}^3$$

$$\Delta H = h_w \left[ \frac{\rho_w}{\rho_a} - 1 \right] \text{ m}$$

$$\text{where } h_w = \Delta H \times 768.2 \text{ m}$$

$$H = h_w \times \text{pitot constant}$$

$$\text{where pitot const.} = 5$$

**4. Blower Efficiency**

$$\eta_{\text{Blower}} = 100 \times \frac{\text{Op}_{\text{Blower}}}{\text{Ip}_{\text{Blower(Ele)}}}$$

**TABULAR COLUMN OBSERVATION****Type of Impellers backward / forward / straight (Radial)**

SI No.	Speed of Blower RPM	Time for 10 impulse in sec	Pitot		h <sub>w</sub> in m	Gate Opening
			h <sub>1</sub>	h <sub>2</sub>		

Gate opening	Discharge	Input power of AC Motor	Blower output power	Blower Efficiency

## VIVA QUESTIONS

1. Define density?

It is defined as the ratio of mass per unit volume of the fluid.

2. Define viscosity?

It is defined as the property of fluid which offers resistance to the movement of fluid over another adjacent layer of the fluid.

3. Differentiate between real fluids and ideal fluids?

A fluid, which is incompressible and is having no viscosity, is known as ideal fluid while the fluid, which possesses viscosity, is known as real fluid.

4. What is a venturimeter?

It is a device which is used for measuring the rate of flow of fluid flowing through pipe.

5. What is a notch?

A notch is a device used for measuring the rate of flow of a fluid through a small channel or a tank.

6. Define buoyancy?

When a body is immersed in a fluid, an upward force is exerted by the fluid on the body. This upward force is equal to the weight of the fluid displaced by the body.

7. Define meta-centre?

It is defined as the point about which a body starts oscillating when the body is tilted by a small angle.

8. Define a pump?

The hydraulic machine which converts the mechanical energy into hydraulic energy is called a pump.

9. Define centrifugal pump?

The pump which converts the mechanical energy into hydraulic energy, by means of centrifugal force acting on the fluid is known as centrifugal pump.

10. Define reciprocating pump?

The pump which converts the mechanical energy into hydraulic energy by sucking the liquid into a cylinder in which a piston is reciprocating, which exerts the thrust on the liquid and increases its hydraulic energy is known as reciprocating pump.

11. What is impact of jet means?

It means the force exerted by the jet on a plate which may be stationary or moving.

12. What is a turbine?

A turbine is a hydraulic machine which converts hydraulic energy into mechanical energy.

13. What is tangential flow turbine?

If the water flows along the tangent of the runner, the turbine is known as tangential flow turbine.

14. What is radial flow turbine?

If the water flows in the radial direction through the runner, the turbine is called radial flow turbine.

15. State Newton's law of viscosity?

It states that the shear stress on a fluid element layer is directly proportional to the rate of shear strain.

16. What are the devices used for pressure measurement?

The devices used are manometers, diaphragm pressure gauge, dead weight pressure gauge etc

17. Why blower is used?

Blower is used to discharge higher volume of air at low pressure.

18. State continuity equation?

For a fluid flowing through a pipe at all the cross section, the quantity of fluid per second is constant.

19. What are the methods of describing fluid motion?

The fluid motion is described by two methods. They are Lagrangian method and Eulerian method.

20. Where the notches are used?

Notches are usually used in tanks or small channels.

21. What is a weir?

Weir is a concrete structure placed in an open channel over which the flow occurs.

22. What do you understand by the term major loss in pipes?

When a fluid is flowing through a pipe, some of the energy is lost due to friction, this is termed as major loss.

23. What do you understand by the term minor loss in pipes?

When a fluid is flowing through a pipe, some of the energy is lost due to sudden expansion of pipe, sudden contraction, bend and pipe fitting, these are termed as minor loss.

24. Define the term hydraulic gradient?

It is defined as the line which gives the sum of pressure head and datum head of a flowing fluid in a pipe with respect to some reference line.

25. Define the term total energy line?

It is defined as the line which gives the sum of pressure head, datum head and kinetic head of a flowing fluid in a pipe with respect to some reference line.



26. What is a draft tube?

It is a pipe of gradually increasing area which connects the outlet of the runner to the tail race. It is used for discharging water from the exit of the turbine to the tail race.

27. Define co-efficient of velocity of jet.

It is defined as the ratio between the actual velocity of a jet of liquid at vena-contracta and the theoretical velocity of jet.

28. Define co-efficient of contraction of orifice meter.

It is defined as the ratio of the area of the jet at vena-contracta to the area of the orifice.

29. Define co-efficient of discharge of orifice meter.

It is defined as the ratio of the actual discharge from an orifice to the theoretical discharge from the orifice.

30. What is vena-contracta?

It is a section at which the stream lines are straight and parallel to each other and perpendicular to the plane of the orifice.

## REFERENCES

- A textbook of Fluid Mechanics by "Dr. R.K. Bansal", Laxmi publications ,2004.
- Fluid Mechanics (SI Units), Yunus A . Cengel John M Oimbala, 2<sup>nd</sup> Ed., Tata McGraw Hill, 2006.
- Fluid Mechanics and Fluid power Engineering , Kumar D.S, kataria and Sons .,2004.